

**MFI, Diesel, In Line Injection, K Series,  
with Magnetic Pick-up, AC Signal Generator,  
or Alternator Pick-up Tachometer**

**This manual (part # 7000-316-05) applies to the following product part numbers:**

- 1) 750M-201-2K
- 2) 750M-231-2K
- 3) 750M-BOS-2K
- 4) 750M0-2012K
- 5) 750M0-2312K
- 6) 750M0-BOS2K
- 7) 75TM-235-2K
- 8) 75TM0-2352K
- 9) 77TM-235-2K
- 10) 770M-201-2K
- 11) 770M-231-2K
- 12) 770M-BOS-2K
- 13) 770M0-BOS2K
- 14) 770M0-2312K





## INSTALLATION PLANNING



### **READ ME FIRST - Detailed Mechanical & Electrical Planning Saves Installation Hours!**

FloScan systems are not difficult to install. Installing one requires only basic electrical & mechanical skills. With forethought and planning, your system will be installed with few problems.

#### **I. Installation Preparation:**

Review the pre-installation booklet and mechanical installation instructions and survey your vessel. Determine where the Sensor(s), Pulsation Damper(s), (If used) Switches and Instruments are to be mounted. Place them at their approximate locations. Measure fuel line lengths between system components, (Primary Filter, Sensor(s), Damper(s), Engine, and Fuel Tank. Determine fitting sizes and type of fittings needed for each plumbing connection, (JIC, SAE, NPT, NPTF, or Hose Barb).

FloScan Series K High Flow, Diesel system components have 1", and ½" Female NPT ports.

FloScan Series K Standard Flow, Diesel, system components have ¼" Female NPT ports.

FloScan Gasoline High Flow, system components have ½" Female NPT ports.

FloScan Gasoline Standard Flow, system components have ¼" Female NPT ports.

Gasoline Fuel Systems: USCG requires Type A-1 Fuel Hose to be installed between the fuel tank and the engines' fuel inlet connection. Type B-1 may be used if certain safety requirements are met, (33 CFR, Subpart J, 183.558). 33 CFR Subpart J, 183.532 require hose clamps to be made from a corrosion resistant material. To meet American Boat & Yacht Council, (ABYC) standards, the clamps must be made from a corrosion resistant metal, (ABYC, H-24.11.1).

Diesel Fuel Systems: Installing sensor assemblies in the fuel system can comprise approximately 1/3 of the total installation cost. Careful planning prior to installation will minimize expenses. Existing fuel systems can be plumbed with Fabric Braid Hose, Steel Braid Hose, Metal Tube or Steel Pipe. If your hose, tube or pipe is in good condition, there is no need to replace it when installing the sensor assemblies.

Review the electrical installation instructions. Open and survey your vessel's wire ways. Determine if it would be easier to run a 3-conductor cable from each sensor to the instrument, or install a junction box, (J-Box) with terminal strip in the engine room. The J-Box requires a 4-conductor cable from it to the instrument, and a 3-conductor cable from each sensor. Measure cable lengths from sensor(s) to J-Box, (If used) to Instrument. Tachometers require a separate 2-conductor cable. If there's an existing tachometer, its signal wires can be used.

Tools required are paper, pencil, and measuring tape.

#### **II. Mechanical Installation:**

Install or mount the Sensor/Pulsation Damper assemblies, or Sensors, Instruments and Switches, (Reset, MPG, Port/Starboard, Synch). When installing the sensor assemblies, try to locate them where you will only have to make one fuel line cut per sensor. You can locate the sensor at any convenient location. Try to have two or more feet of hose between sensor and engine.

#### **III. Plumbing:**

**Fabric Braid Fuel Hose:** This is the easiest hose to work with and generally uses hose barb fittings. Example: 12 HB X 16 MNPT, (3/4" Hose Barb by 1" Male NPT). Install the correct HB X NPT fitting into each fuel system component, Tank, Manifolds, Filter, Sensor(s) Damper(s) and Engine. Assemble fittings using a fuel proof pipe thread sealant. **Never use Teflon Tape.** Referring to the Fuel Flow Schematic, run the fuel hose between system components. Cut to correct length with a pocket or razor knife. Hoses should not be twisted, have adequate slack, an ample radius at all bends and be supported at reasonable distances, approximately 2-4 feet. When clamping hose onto the barbs, use 2 narrow stainless steel hose clamps, (preferred) or 1 wide stainless hose clamp on each hose end.

**Wire Braid Fuel Hose:** There are two types of wire braid fuel hose. One type has reusable hose ends the other swaged ends. Wire braid hose tend to use JIC or SAE X NPT fittings. Install the correct fitting into each fuel system component, Tank, Manifolds, Filter, Sensor(s) Damper(s) and Engine. Assemble fittings using a fuel proof pipe thread sealant. **Never use Teflon Tape.** Referring to the Fuel Flow Schematic, run the fuel hose between system components. Cut to correct length and install hose ends.

- If you choose to do this yourself, (reusable ends only) rent a hose-cutting tool and purchase a tube of assembly lubricant.
- Most dealers will cut and assemble both hose ends for \$10 per hose. Some charge as much as \$40.

Hoses should not be twisted, have adequate slack, an ample radius at all bends and be adequately supported at reasonable distances, approximately 2-4 feet. AP-50 copper sealing washers or Flaretite fitting seals may be required to seal JIC & SAE fittings.

**Steel Pipe:** Sensor assemblies can be installed directly onto threaded pipe ends. Use a 30 inch length of either flexible metal hose or steel braid hose between the other end of the sensor and the engine.

## **IV. Electrical Installation:**

Run cables between Sensor(s), J-Box, (If used) and Instrument(s). Cables must be adequately supported at reasonable distances, approximately 2-4 feet.

Wire Terminations—Referring to the wiring diagram, Connect Sensor, Instrument and Switches to their respective wires with crimp type butt or ring connectors. Always cover connectors and wire ends with heat shrink tubing.

**Isolated Ground Electrical Systems:** FloScan manufactures 12 VDC to 12 VDC, (PN 7000-097-00) and 24 VDC to 12 VDC, (PN 7000-096-00) Isolated Ground Power Supplies / Voltage Reducers. These power supplies electrically isolate the FloScan system from ship's power and are used by the Washington State Ferry System and other large steel and aluminum vessel operators. Additionally mounting sensors onto a non-conductive surface and using short lengths of non-metallic fabric braid fuel hose to connect them further isolates the system.

Diesel Fuel is non-conductive but does contain a, "Static Electricity Dissipation" additive to minimize the risk of fuel tank fires and explosions. Even with this additive, the electrical resistance of Diesel Fuel is extremely high and can be considered non-conductive. Installing the FloScan system with Isolated Ground power Supplies, Non-Conductive Sensor Mounting Surfaces and Fabric Braid Fuel Hose will electrically isolate it from the vessel's hull.

## **V. Pre-Startup:**

- ***Always Prime the fuel system before Engine Start-Up.*** This prevents your engine from becoming air-bound.

If you have an electric priming or boost pump, circulate fuel for 10 minutes while checking for leaks. If the fuel system does not have an electric priming pump, use the engine's manual pump. Before starting, slightly open or crack the lift pumps' outlet fitting. Pump until all air is purged at the lift pumps' outlet. Before start-up, verify that all fuel system fittings are tight.

## **VI. System Start-Up:**

Start and run your engines. Look for leaks and other installation problems. If system is not operating properly refer to the Troubleshooting Instructions and correct any deficiencies.

## **VII. Calibration:**

When system is running properly, refer to the calibration instructions and calibrate your system. If installed correctly, initial calibration takes only a few minutes. After consuming some fuel, final calibration should only take a few minutes.

- **The US Code of Federal Regulations, (CFR's) contain no requirement for using Type A-1, A-2, B-1 or B-2, USCG approved fuel hose on diesel powered pleasure vessels. To meet ABYC standards though, fuel hose shall comply with the requirements of UL 1114, Marine (USCG Type A) Flexible Fuel-Line Hose, or SAE J1527, Marine Fuel Hoses, (ABYC H-33.6.1).**

## Installation Do's & Don'ts

| Do   | Don't  |
|--|--|
| Always use a Fuel Proof Pipe Thread Sealant when assembling fittings into fuel system components, (Loctite PST, Rector Seal, or equivalent).   | <b><u>Never use Teflon Tape!</u></b>   |
| Use thin wall, low pressure, NPT or NPTF hose barb fittings.   | <b>If possible avoid using JIC or SAE swivel fittings. If used, always install Copper AP-50 sealing washers or Flaretite fitting seals onto the JIC or SAE swivel fittings male end.</b> |
| Double clamp all hose barb fittings.   | <b>Minimize the use of 90° elbow fittings.</b>   |
| Install Sensors as far from the engine as practical. Fuel must travel, "Up-hill" at least 1 or 2 inches after leaving the Return Sensor. Install Return Sensors downstream of Pressure Regulator Valves. | <b>If possible, try to avoid bolting or mounting sensor(s) directly onto the engine.</b>   |
| Always install <b>Diesel</b> Forward Sensor/Pulsation Damper assemblies and <b>Gasoline</b> Sensors on the Vacuum or Inlet side of all Fuel Pumps.   | <b>Do Not Exceed the Forward or Return Sensor/Pulsation Damper Assembly's Tested Operating Pressure of 100 PSI.</b>  |
| Always use 30-micron primary filters on Diesel systems. 20 and 10-micron filters are acceptable if required by the engine manufacturer.  | <b>Avoid 2 or 5-micron primary filters.</b>  |
| Wire with Shielded Cable on Diesel installations. If possible use a dedicated shielded wire pair for Magnetic Pickup Tachometer Senders.   | <b>Never use unshielded wires on Magnetic Pickup Tachometer Senders.</b>   |
| Connect all Negative wires to a Battery Minus Buss or directly to the Battery's Negative Terminal.<br>Connect or, "Ground" wire shields / shield drains to the engine block or vessel bonding system.    | <b>Never connect Negative, (Battery Minus) wires to the Hull, Engine Block, or other machinery.</b>  |
| On Instruments with a GPS interface, connect FloScan's Data (+) to the GPS signal output.<br>Connect Data (-) to a Battery Minus buss.   | <b>Do not connect FloScan's Data (-) to the GPS Data (-).</b>  |
| Always use non-illuminated switches for Totalizer Reset, Port/Starboard Select, Hours/Synch, and GPH/MPG.  | <b>Never use illuminated or back-lit switches.</b>   |

## Series 7500(0)/7600(0), 8500(0)/8600(0), 9500(0)/9600(0) Temperature Compensated, & Non-Temperature Compensated Magnetic Pickup & AC Signal Generator Type Tachometer Sender Instruments

Series 7500(0)/7600(0), 8500(0)/8600(0), 9500(0)/9600(0) Diesel Multifunction Instruments use a microprocessor-based, non-volatile Random Access Memory (RAM) to store engine hours and gallons of fuel consumed. Non-volatile RAM requires no power for memory retention.

All "8"s are displayed for the first 3 seconds when the instrument is powered up. For 1 second after that, the instrument shows switch positions and software version. After completing its start-up sequence, the instrument goes into normal operating mode.

If supply voltage drops below 10V DC for any reason, the instrument displays a row of decimals across the bottom of the RPM window. This does not affect instrument accuracy. Stored engine hours and fuel consumption data will not be lost.

Liquid crystal displays have an OPTIMUM VIEWING ANGLE. If your viewing angle is outside this range, contrast will decrease and numbers may flicker.

Before drilling any holes in your dash, it's a good idea to temporarily power up the instrument (+12V DC to the RED wire on plug #9, 12V DC to the BLACK wire on plug #5) before installing it and see if the intended viewing angle is acceptable.

### Engine Hours

The engine hours meter is shipped at or near zero hours. It accurately tracks the number of hours your engine has run. Unlike most hour meters, it only accumulates time when the engine is actually running. If the meter is turned ON, but the engine is NOT running, NO time is added to the engine hour display.

The engine hour meter cannot be reset.

### Tachometer (RPM)

The Tachometer window shows engine speed in RPM and is accurate to within  $\pm 1\%$  (belt driven alternator tachometer signals are only accurate to  $\pm 50$  RPM).

### Flow Consumption (GPH, LPH)

The GPH/LPH window shows the rate at which your engine is consuming fuel. The GPH/LPH and Gallons/Liters readings will both change if the flow calibration switch (UPPER BLACK SWITCH) on the back of the instrument is turned.

### Totalizer (Gallons, Liters)

The Gallons/Liters window shows total fuel consumed. The GPH/LPH and Gallons/Liters readings will both change if the flow calibration switch (UPPER BLACK SWITCH) on the back of the instrument is turned.

### Totalizer Reset

When the totalizer-reset switch is turned ON (Closed), the GALLONS/LITERS display will flash for ten seconds, then reset to zero. Flashing indicates the instrument is in reset mode. If the RESET switch is turned OFF (Opened), before the totalizer reads "0.0", the instrument will NOT reset. If you neglect to turn OFF the RESET switch, "0.0" continues to flash.

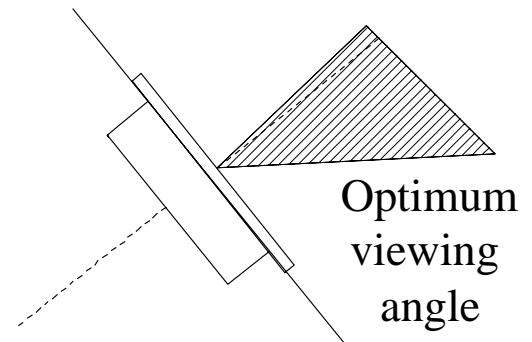

## AC Signal Generator, (G) Type Only

**750G/760G, 75TG/76TG, 750G0/760G0, 75TG0/76TG0**  
**850G/860G, 85TG/86TG, 850G0/860G0, 85TG0/86TG0**  
**950G/960G, 95TG/96TG, 950G0/960G0, 95TG0/96TG0**

Type “G” Diesel Multifunction Instruments are preset for the correct flow sensor combination. Before installing the instrument, verify that the switch settings are correct for your application. Flow Sensor types are coded as part of your kit model number.

| Recessed “Arrow” Rotary Switch Settings |  |                 |               |
|---|--|-----------------|---------------|
| Switch Position                         | Flow Sensor  | Switch Position | Flow Sensor   |
| 0                                       | CAT 265/265  | 8               | 233B/233B     |
| 1                                       | RTY 265/201  | 9               | 233C/233C     |
| 2                                       | 265/231  | A               | 233D/233D     |
| 3                                       | 231/231  | B               | 233E/233E     |
| 4                                       | 201/201  | C               | 233F/233F     |
| 5                                       | BOS 231/201  | D               | Cummins 231*  |
| 6                                       | All 235/236 &<br>233 B-C, C-D, D-E, E-F,<br>and combinations | E               | Cummins 233C* |
| 7                                       | 233A/233A  | F               | Cummins 233D* |

\*Cummins Engines with PT pump injection system using one flow sensor in the feed line to the engine.

## MECHANICAL & WIRING OVERVIEW – Standard Flow (BOS, 201, 231, 235-2K)

To Ensure System Accuracy, Follow All Installation Instructions.

- Sensor Placement.** Determine where the Flow Sensor or Flow Sensor-Pulsation Damper assembly is to be installed. Install the sensor or sensor-pulsation damper assembly so that the ports marked IN and OUT. All orientation arrows, (↑) must be pointing up. The forward sensor or forward sensor-pulsation damper assembly must be installed downstream of a Racor type primary filter. Upon exiting the return sensor, fuel must travel “Up-Hill” on its way back to the fuel tank. The fuel return line, between the return sensors’ outlet port and fuel tank should be no less than 12” and have a 1 to 2” upward rise. This keeps the return sensor flooded improving accuracy. Place sensor assemblies in a protected location away from water spray.

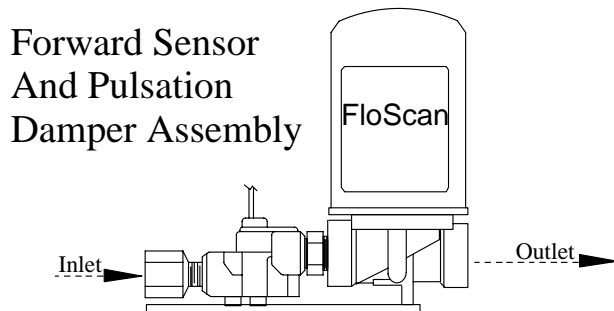

201/ 231-1K & 2K, 235-2K

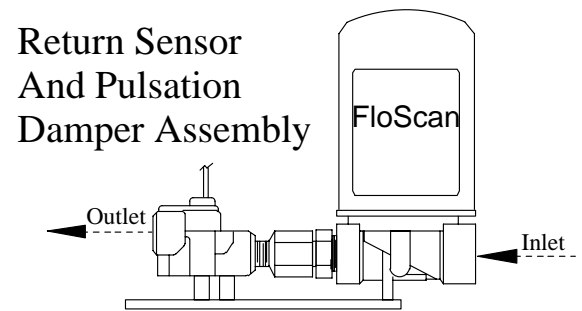

201/ 231/ 235-2K

**\*Caution: Diesel System Components are not designed for use on Gasoline Fuel Systems.**

- Determine fitting type & size.** Minimize the number of elbows and fittings. If swivel fittings are used, (JIC or SAE) their mating surfaces must be sealed with FlareTite fitting seals. Fitting seals may be purchased through Fittings Inc. in Seattle, WA (206) 767-4670, 1-800-552-0632, or a local hydraulic supply house.



(Continued on next page)



- **Select Instrument Mounting Location.** The instruments' face is waterproof and a gasket is provided to seal its bezel to the control panel. Choose a location away from the compass. Install 65/6600 series instruments 12" away from compass. Choose a shaded location since direct sunlight may cause the LCD display to temporarily turn. This does not damage the LCD, but makes it impossible to read until cooling down. Make a cutout in the instrument panel for the instrument. The instruments' maximum depth is 3 1/2" minus the thickness of the console panel.

| Instrument Series                         | Cutout Size |
|---|-------------|
| 6500/6600                                 | 3 1/16"     |
| 7500/7600, 8500/8600, 9500/9600, TwinScan | 3 3/8"      |

- **Wiring.** Determine wiring run length and the number of switches needed, (always use good quality marine grade switches). Use 18 AWG conductors on runs under 50'. 16 AWG for runs over 50'.
- **Run & Connect Wires.** Wire one system at a time. Always begin with the Black, "Ground" wires. Each Black sensor wire must be connected to the Black, "Instrument Ground" wire. Use a single wire to connect these Black wires to the battery's negative terminal, or to the ground buss. **For the system to operate properly the, "Ground" wires must be connected in this manner.** Connect other wires per the wiring diagram. Leave the RED, power wire for last.
- **Tachometer Installation Options.** 75/7600, 85/8600, and 95/9600 series tachometers require one or two additional wires. If your engine isn't equipped with a tachometer sender, determine which type it requires, (AC Signal Generator or Magnetic Pickup) and install one. Some engine alternators produce a tachometer signal and can be used as the tachometer sender. Mechanically driven AC signal generators and magnetic pickups are available from FloScan and most marine dealers. Hewitt, Motorola, VDO and Stewart Warner are some of the more common brands.
  1. **Keep Existing Tachometer(s).** Connect the FloScan tachometers' Yellow and Violet signal wires to the existing tachometer. If the tachometer sender wire(s) are not marked, trace them from the tachometer sender up to the existing tachometer. If one sender lead is grounded, connect the FloScan tachometers Yellow signal wire to the ungrounded lead or terminal. Connect the VIOLET wire to a Ground Buss, or Battery Minus.
  2. **Replace Existing Tachometer(s).** FloScan MFI instruments have a 3 3/8" outside diameter. This is a common size and fits into most instrument mounting holes. Identify the engines' tachometer sender wires. Connect the FloScan tachometers' Yellow and Violet signal wires to the sender wires. If one sender lead is grounded, connect the FloScan tachometers Yellow signal wire to the ungrounded lead or terminal. Connect the VIOLET wire to a Ground Buss, or Battery Minus.
  3. **New Tachometer(s).** Run a dedicated shielded pair of wires between the instrument and tachometer sender, (This is especially important with Magnetic Pickup senders). Ground the shield only in the engine room.
    - **Magnetic Pickup & AC Signal Generator Tachometer Senders:** Connect the FloScan tachometers' Yellow signal wire to one sender terminal. Connect the Violet wire to the other terminal.
    - **Engine Alternators:** Connect the FloScan tachometer's YELLOW signal wire to the alternator's tachometer output terminal. This terminal is usually marked as **TACH**, or **SIG**. Connect the VIOLET wire to a Ground Buss, or Battery (-).
- **Pre-Startup & Installation Check.**
  - **Always Prime the fuel system before Engine Start-Up.** *This prevents your engine from becoming air-bound.*
  - If you have an electric priming or boost pump, circulate fuel for 10 minutes while checking for leaks. If the fuel system does not have an electric priming pump, use the engine's manual pump. Before starting, slightly open or crack the lift pumps' outlet fitting. Pump until all air is purged at the lift pumps' outlet. Before start-up, verify that all fuel system fittings are tight.
  -

(Continued on next page)

- **System Start-Up.** Start and run your engines. Survey the installation for leaks and other problems. If the system is not operating properly refer to the Troubleshooting Instructions and correct any deficiencies. When the engine reaches operating temperature increase engine speed to about 1500-2000 RPM. Letting it run for five or ten minute's helps purge residual air from the system.
- Any vacuum leaks between the fuel tank and lift pump will allow air to be drawn into the system. These leaks cause high and/or fluctuating GPH readings. Only severe leaks affect engine performance, but all leaks affect sensor performance and instrument readings. Vacuum or suction leaks occur at improperly sealed primary filters, loose packing nuts on cross over & shut off valves and improperly sealed fittings. Vacuum leaks can also occur from corroded copper fuel lines and chaffed fuel hose, (where it rubs against bulkheads or engine parts). To verify that a suction leak is present, temporarily insert a clear piece of fuel resistant tubing downstream of the Forward Sensors' outlet. Observe the clear hose for at least two minutes looking for bubbles. Bubbles can appear as a constant stream of small bubbles, or as an occasional larger bubble. Tighten all possible leak sources, grease primary filter seals and install fitting seals on JIC/SAE fittings. Continue to observe the clear tubing until it runs clear without any bubbles. Flex or wiggle rubber hose sections while observing the clear tubing. If bubble volume increases inspect the hose and check its fittings. Repair as necessary.
- When idling in neutral, (No Load) GPH fluctuations can also be caused by the governor trying to maintain a steady engine RPM.
- **Calibration.** When the system is running properly, refer to the calibration instructions and calibrate your system. If installed properly, initial calibration takes much less than one hour. After consuming some fuel, final calibration should only take a few minutes.



## Standard Flow Diesel Systems (BOS, 201, 231 & 235-2K)

### Forward Sensor to Forward Pulsation Damper Assembly

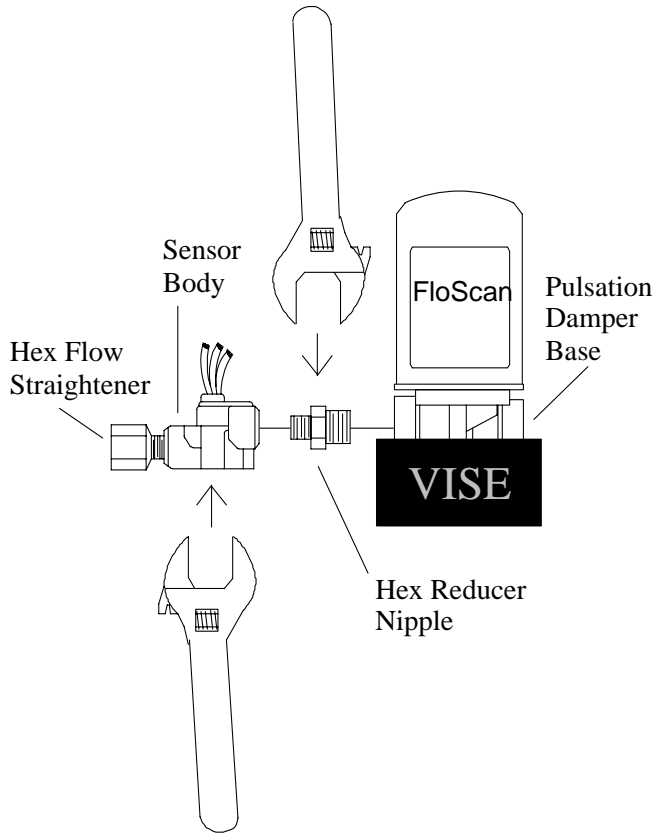

1. Clamp the Pulsation Damper's aluminum base into a vise.
2. Coat the Hex Reducer Nipple's 1/2" MNPT threads with sealant.
3. Place the 1/2" MNPT Hex Reducer Nipple threads into the Pulsation Damper's base end with the Inward Pointing Arrow (➔).
4. Tighten hand tight.
5. Coat the Hex Reducer Nipple's 1/4" MNPT threads with sealant.
6. Place the Forward Sensor's "OUT" port onto the 1/4" MNPT Hex Reducer Nipple end.
7. Tighten hand tight.
8. Use an adjustable wrench to tighten the Hex Reducer Nipple into the Pulsation Damper base.
9. Use an adjustable wrench to tighten the sensor body onto the Hex Reducer Nipple. **DO NOT** put a wrench on the Forward Sensor's Hex Flow Straightener, at the Sensor's inlet port
10. When tightened, the Sensor's base and the Pulsation Damper base must be even.

- **CAUTION:** When tightening the Forward Sensor onto the Hex Reducer, always place the wrench onto the Sensor's body.
- **Never** place a wrench on the Forward Sensor's Hex Flow Straightener while assembling the Sensor onto the Forward Pulsation Damper. The Flow Straightener is locked into place with a very strong retaining compound and must remain in position. It must not be tightened or loosened. Moving the Flow Straightener in relation to the Sensor body will destroy the Sensors accuracy. Turned Flow Straighteners are not considered warranty items.

**CAUTION, DO NOT OVER TIGHTEN FLOW SENSOR FITTINGS. Over-tightening may crack the sensor's body. Cracks cause leaks, and fuel leaks sometimes cause catastrophic explosions and fire.** Assemble fittings with a Lubricating, Fuel Proof, Non or Semi Hardening pipe thread sealant, designed for aluminum and stainless steel threads, (Loctite 567 or equivalent).  
**DO NOT USE TEFLON TAPE.**

*(Continued on next page)*

## Forward Fuel Line Fitting to Forward Sensor Assembly

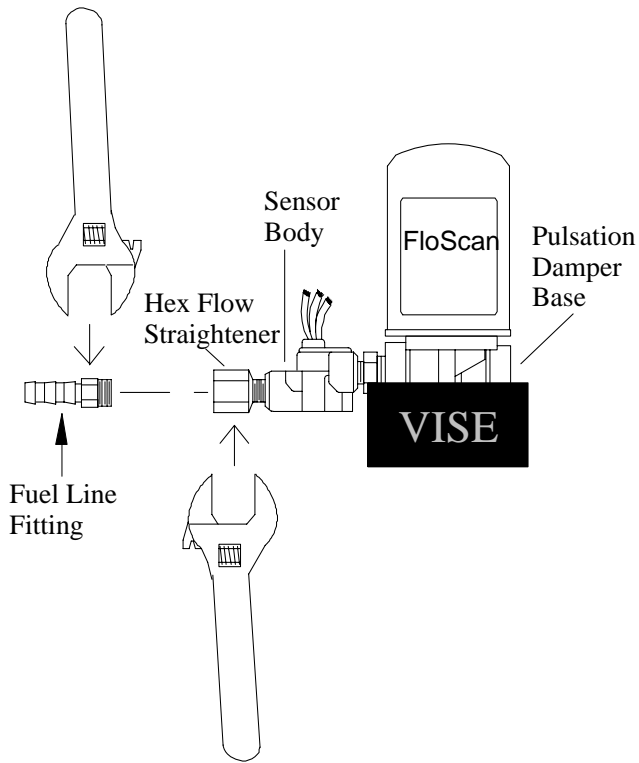

1. Leave the Pulsation Damper's base clamped in the vise.
  2. Coat the fuel line fitting's 1/4" MNPT threads with sealant.
  3. Place the fitting into the Sensor's Hex Flow Straightener.
  4. Tighten hand tight.
  5. Place an adjustable wrench on the Sensor's Hex Flow Straightener to act as a counter torque.
  6. Use an adjustable wrench to tighten the fuel line fitting into the Hex Flow Straightener.
  7. Whenever possible, use a straight fitting on the Forward Sensor's inlet port. If required a 45° elbow fitting can be used.
  8. 90° elbow fittings on the Forward Sensor's inlet port should be avoided.
  9. Determine which type of fitting is required for the Pulsation Damper's outlet port.
  10. If the Pulsation Damper's base is clamped in a vise, a counter torque wrench is not required for the outlet fitting assembly.
  11. Straight, 45° or single 90° elbow fittings are each acceptable at the forward Pulsation Damper's outlet port.
  12. The Pulsation Damper's outlet port has 1/2" FMPT threads. If a 90° elbow fitting is required, use a 1/2" elbow with 1/2" MNPT threads.
- **CAUTION:** When tightening the forward fuel line fitting into the Forward Sensor's Hex Flow Straightener, always place a counter torque wrench on the Sensor's Hex Flow Straightener.
  - **Never** place a wrench on the Forward Sensor's body while assembling the fuel line fitting into the Forward Sensor's Hex Flow Straightener. The Hex Flow Straightener is locked into place with a very strong retaining compound. It must remain in position and must not be tightened or loosened. Moving the Hex Flow Straightener in relation to the Sensor body will destroy the Sensors accuracy. Turned Hex Flow Straighteners are not considered warranty items.

**CAUTION, DO NOT OVER TIGHTEN FLOW SENSOR FITTINGS. Over-tightening may crack the sensor's body. Cracks cause leaks, and fuel leaks sometimes cause catastrophic explosions and fire.** Assemble fittings with a Lubricating, Fuel Proof, Non or Semi Hardening pipe thread sealant, designed for aluminum and stainless steel threads, (Loctite 567 or equivalent).

**DO NOT USE TEFLON TAPE.**

*(Continued on next page)*

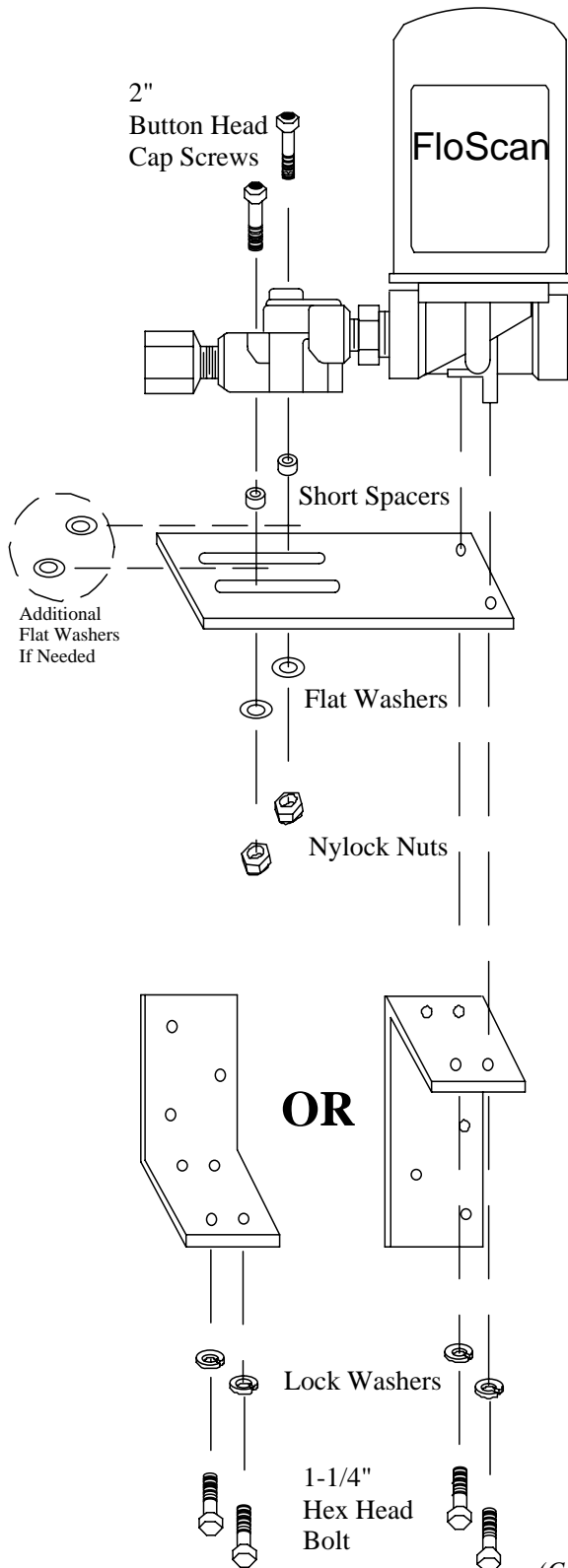

1. Place the Forward Sensor-Pulsation Damper assembly, with inlet and outlet fittings installed, onto the flat bracket. Orient the Sensor body over the slots and the Pulsation Damper base over the bolt holes.
2. Slide a lock washer onto two 1/4" bolts.
3. Choose your 90° mounting bracket option. Assemble the 1/4" bolts through the angle and flat brackets into the Pulsation Damper base.
4. Tighten the bolts a little past hand tight, compressing the lock washers slightly.
5. Install the short spacers between the Sensor body and flat bracket.
6. Slide the two 2" button head cap screws through the Sensor body and spacers.
7. Grasp the Pulsation Damper and hold the flat bracket against the Pulsation Damper's base. Verify that the Sensor's base is perpendicular to the flat bracket.
8. If the Sensor and spacers are flush with the flat bracket, install flat washers and ESNA nuts onto the 2" button head cap screw ends and tighten until snug. The Pulsation Damper and sensor bolts should be tightened evenly.
9. If a small air gap is present between the Sensor and both spacers, place one flat washer between each spacer and the flat bracket.
10. Install flat washers and ESNA nuts onto the bolt ends and tighten until snug. The Pulsation Damper and Sensor bolts should be tightened evenly.

(Continued on next page)

## Return Sensor to Return Pulsation Damper Assembly

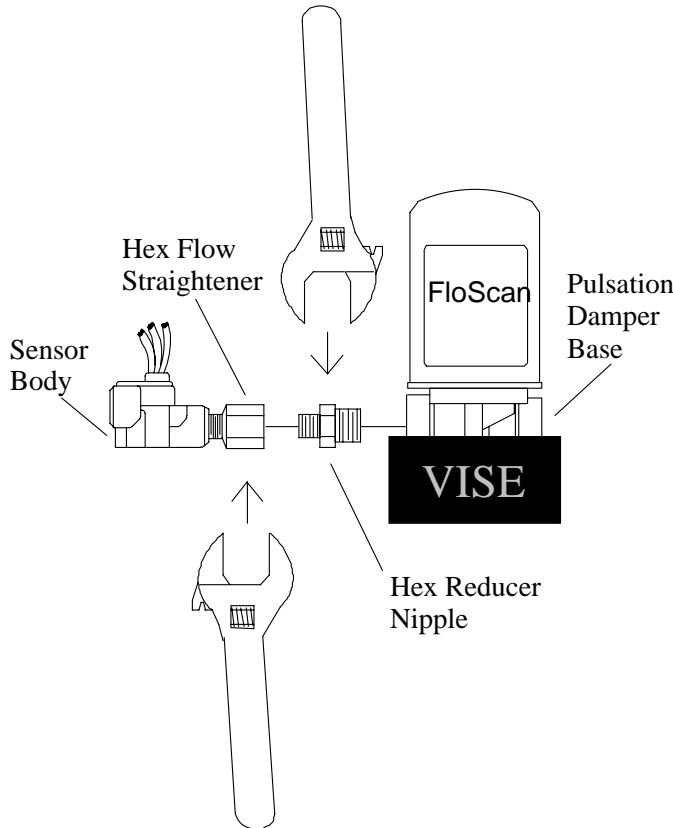

1. Clamp the Pulsation Damper's aluminum base in a vise.
2. Coat the Hex Reducer Nipple's 1/2" MNPT threads with sealant.
3. Place the 1/2" MNPT Hex Reducer Nipple threads into the Pulsation Damper's base end with the Outward Pointing Arrow, (←).
4. Tighten hand tight.
5. Coat the Hex Reducer Nipple's 1/4" MNPT threads with sealant.
6. Place the Return Sensor's Hex Flow Straightener onto the 1/4" MNPT Hex Reducer Nipple threads.
7. Tighten hand tight.
8. Use an adjustable wrench to tighten the Hex Reducer Nipple into the Pulsation Damper base.
9. Use an adjustable wrench to tighten the Sensor's Hex Straightener onto the Hex Reducer Nipple's 1/4" MNPT threads. **DO NOT** put a wrench on the Return Sensor's body.
10. When tightened, the Return Sensor's body and the Pulsation Damper base must be even.

- **CAUTION:** When tightening the Return Sensor onto the Hex Reducer Nipple, always place the wrench on the Sensor's Hex Flow Straightener.
- **Never** place a wrench on the Return Sensors body while assembling the Sensor onto the Return Pulsation Damper. If the Return Sensor is tightened at its body, the Sensors Hex Flow Straightener may be moved. The Flow Straightener is locked into place with a very strong retaining compound and must remain in position. It must not be tightened or loosened. Moving the Flow Straightener in relation to the sensor body will destroy the Sensors accuracy. Turned Flow Straighteners are not considered warranty items.

- 
- 
- **CAUTION, DO NOT OVER TIGHTEN FLOW SENSOR FITTINGS. Over-tightening may crack the sensor's body. Cracks cause leaks, and fuel leaks sometimes cause catastrophic explosions and fire.** Assemble fittings with a Lubricating, Fuel Proof, Non or Semi Hardening pipe thread sealant, designed for aluminum and stainless steel threads, (Loctite 567 or equivalent).

- **DO NOT USE TEFLON TAPE.**

• *Continued on next page)*

# Return Fuel Line Fitting to Return Sensor Assembly

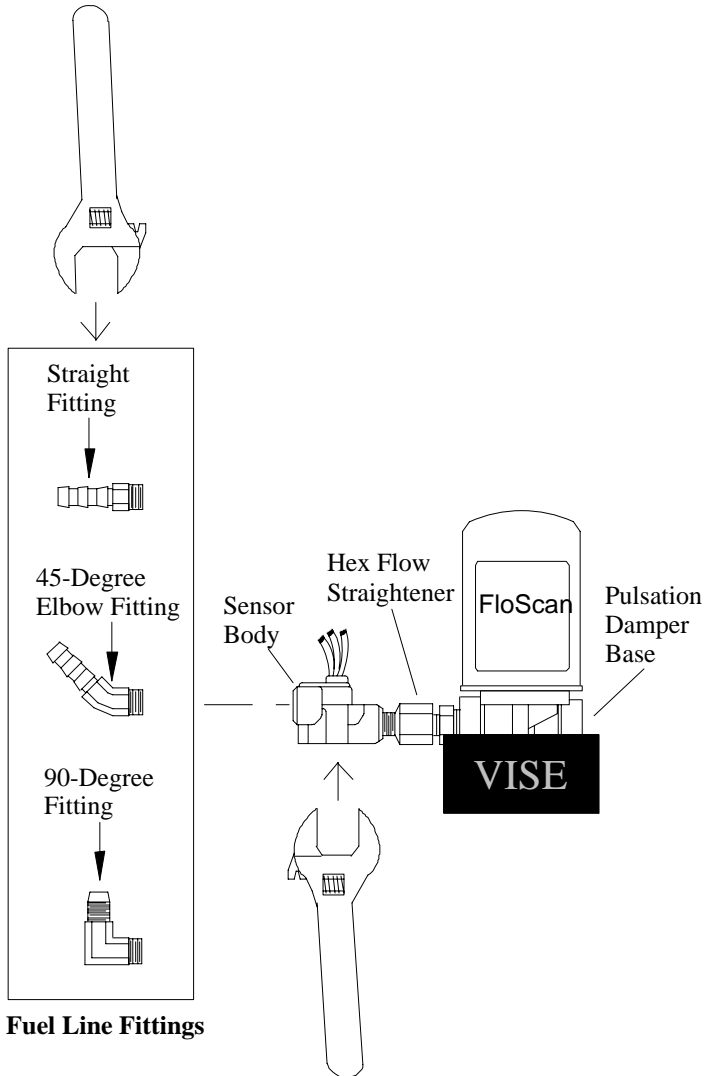

1. Leave the Pulsation Damper's base clamped in the vise.
2. Determine which fuel line fitting type is most appropriate for your application, (please refer to steps 8-12 on pages 7 and 8 in the Mechanical Installation section of this document). Any type of fitting, (straight, 45°, or 90° elbow) is acceptable on the Return Sensor's outlet port.
3. Coat the fuel line fitting's ¼" MNPT threads with sealant.
4. Tighten hand tight.
5. Place an adjustable wrench on the Sensors body to act as a counter torque.
6. Use an adjustable wrench to tighten the fuel line fitting into the Sensors outlet port.
7. Straight, and 45° elbow fittings are each acceptable at the Return Pulsation Dampers inlet port
8. The return Pulsation Damper's inlet port has ½" FMPT threads. If a 90° elbow fitting is required, use a ½" elbow with ½" MNPT threads.
9. If the pulsation damper base is clamped in the vise, a counter torque wrench is not required for installing the inlet fitting.

- **CAUTION:** When tightening the fuel line fitting into Return Sensor, always place a counter torque wrench on the Return Sensor's Body.
- **Never** put a wrench on the Return Sensors Hex Flow Straightener while assembling the fuel line fitting into Return Sensor. If the Return Sensor is held at the Hex Flow Straightener it may be moved. The Hex Flow Straightener is locked into place with a very strong retaining compound. It must remain in position and must not be tightened or loosened. Moving the Hex Flow Straightener in relation to the Sensor body will destroy its accuracy. Turned Flow Straighteners are not considered warranty items.

• **CAUTION, DO NOT OVER TIGHTEN FLOW SENSOR FITTINGS.** Over-tightening may crack the sensor's body. Cracks cause leaks, and fuel leaks sometimes cause catastrophic explosions and fire. Assemble fittings with a Lubricating, Fuel Proof, Non or Semi Hardening pipe thread sealant, designed for aluminum and stainless steel threads, (Loctite 567 or equivalent).

- **DO NOT USE TEFLON TAPE.**

• *Continued on next page)*



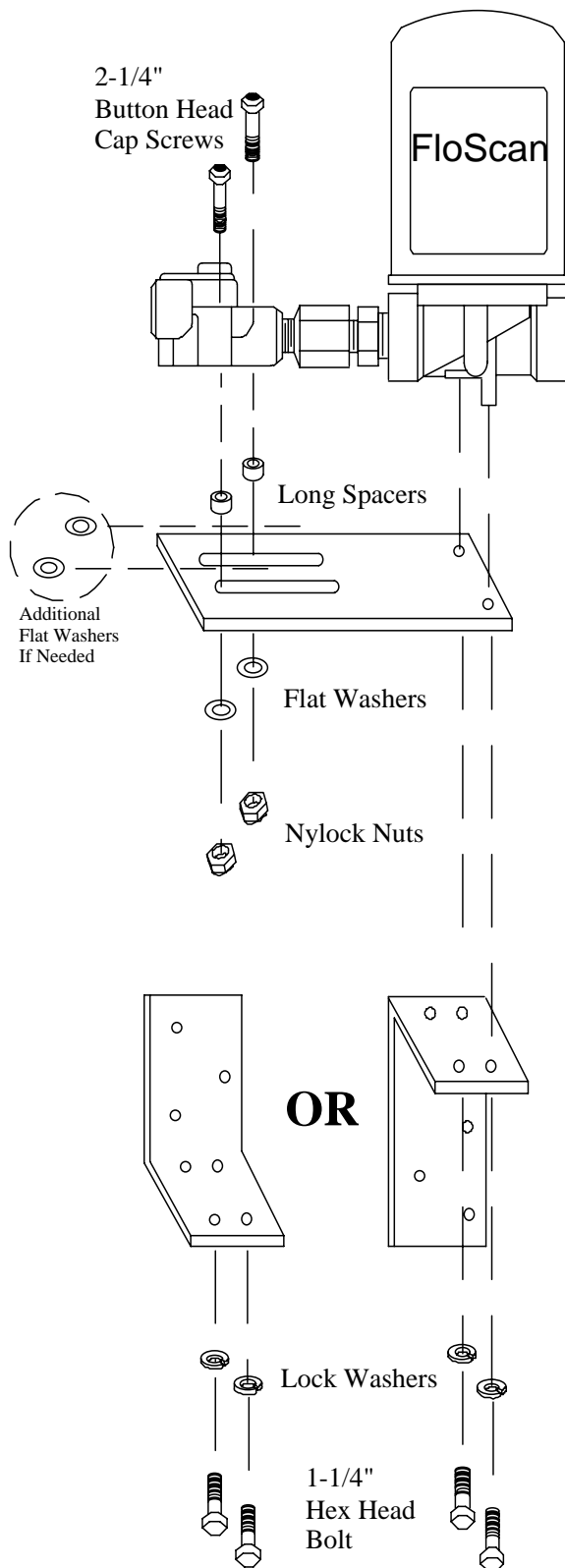

1. Place the Return Sensor-Pulsation Damper assembly, with inlet and outlet fittings installed, onto the flat bracket. Orient the Sensor body over the slots and the Pulsation Damper base over the bolt holes.
2. Slide a lock washer onto two 1 1/4" bolts.
3. Chose your 90° mounting bracket option. Assemble the 1 1/4" bolts through the angle and flat brackets into the Pulsation Damper base.
4. Tighten the bolts a little past hand tight, compressing the lock washers slightly.
5. Install the two long spacers between the Sensor body and flat bracket.
6. Slide the two 2 1/4" button head cap screws through the Sensor body, spacers, and flat bracket.
7. Grasp the Pulsation Damper and hold the flat bracket against the Pulsation Damper's base. Verify that the Sensor's base is perpendicular to the flat bracket.
8. If the Sensor and spacers are flush with the flat bracket, install flat washers and ESNA nuts onto the 2 1/4" button head cap screw ends and tighten until snug. The Pulsation Damper and Sensor bolts should be tightened evenly.
9. If a small air gap is present between Sensor and spacers, place one flat washer between each spacer and the flat bracket.
10. Install flat washers and ESNA nuts onto the bolt ends and tighten until snug. The Pulsation Damper and Sensor bolts should be tightened evenly.

(Continued on next page)

# MECHANICAL INSTALLATION

## Fuel Flow Schematic - Standard Flow Diesel Systems (BOS, 201, 231 & 235-2K)

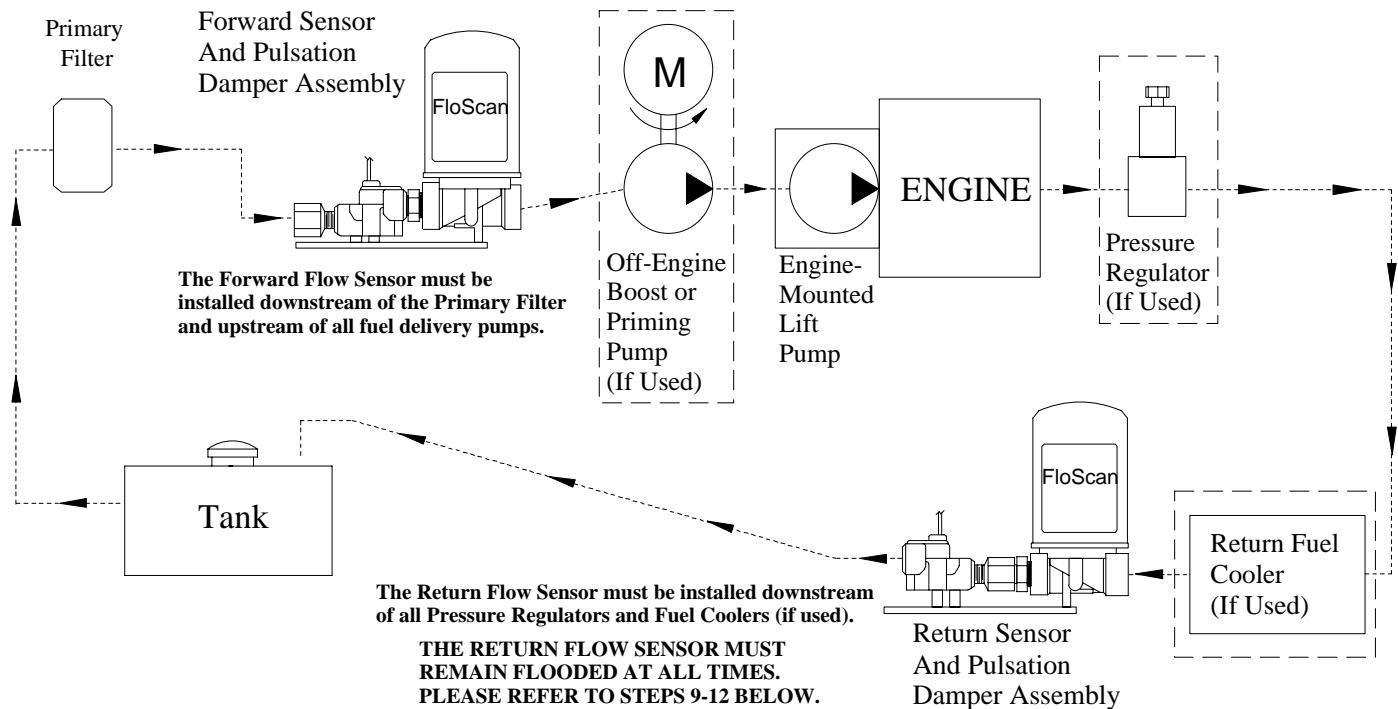

**\*Caution: Diesel System Components are not designed for use on Gasoline Fuel Systems.**

### FloScan Sensor & Pulsation Damper Plumbing Guidelines:

1. Before installing the assembled Flow Sensor & Pulsation Damper assembly's into the fuel system, verify that their orientation arrows are pointing UP ↑.
2. The Forward Flow Sensor / Pulsation Damper assembly must be protected by and installed downstream of a 10 to 30 Micron Primary Filter. The forward assembly can be installed at any convenient location from the bottom of the bilge to the top of the overhead.
3. **NOTE:** Always use the primary filter micron rating **Specified by the Engine Manufacturer**, (usually 10, 20 or 30). Do not follow advice given by local experts, mechanics, or magazines. There are several reasons for avoiding 2 and 5 micron filters.
4. Filtered fuel must enter into the Forward Sensor through its Hex Flow Straightener on the port marked IN. Fuel must exit through the Pulsation Damper port with an outward pointing arrow, (→).
5. Return fuel from the engine, must enter into the Return Pulsation Damper's inlet port. This is the port marked with an inward pointing arrow, (←) and exit through the port marked OUT on the Return Sensor.
6. Install the Forward & Return Sensor – Pulsation Damper assemblies as far from the engine as practical. Maximizing fuel line length, between the engine and Sensor – Pulsation Damper assembly, improves instrument accuracy.
7. Use the smallest approved fuel line diameter for your engine, especially on the return line. Higher fuel flow velocities increase overall system accuracy. Refer to the engine owners or shop manual for more information.
8. **IMPORTANT NOTE: THE RETURN FLOW SENSOR MUST REMAIN FLOODED AT ALL TIMES.**

*(Continued on next page)*

9. If possible, install the Return Sensor – Pulsation Damper assembly at a low point in the fuel system.

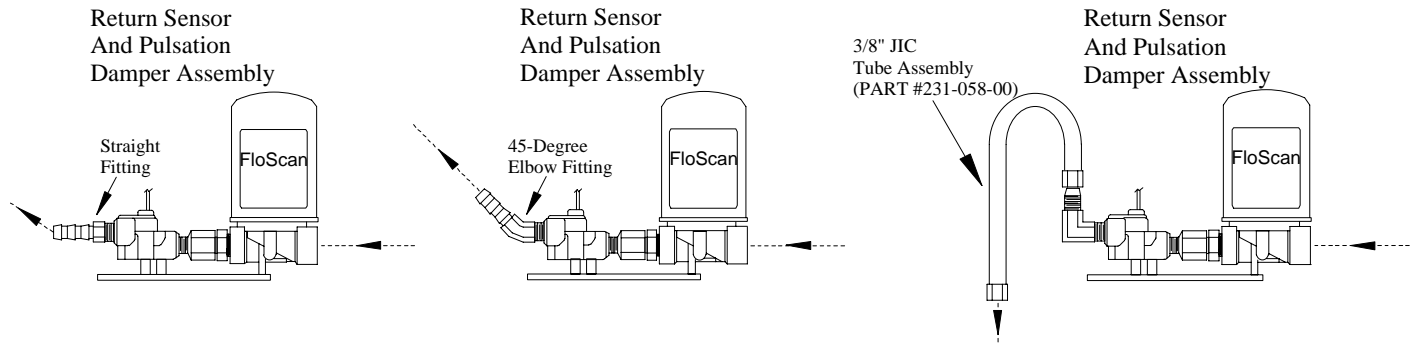

10. There must be some vertical rise to the return fuel flow upon exiting the Return Sensor. There should be a minimum, “Up-Hill” climb of 1 or 2 inches. Higher rises up to 3 feet or a little more are ok.
11. If installing the Return Sensor-Pulsation Damper as outlined in step 9 is not practical, please refer to steps 12 and 13 below.
12. If the return line is fairly horizontal but with a small, “Down-Hill” drop after exiting the sensor, install an upward pointing 45° elbow into the return sensors outlet port. Install the fuel line with a downward radius bend. Do not pinch the hose.
13. If there is a steep vertical drop in the return fuel line, a tube with a 180° radius bend may be the best option. This option requires:
- One, 90° male elbow with one male JIC 3/8” or Dash 6 (–6) end, and one 1/4” male NPT end.
  - Two, Dash 6 (–6), (3/8) FlareTite fitting seals, [www.flaretite.com](http://www.flaretite.com), (to be installed onto the male JIC fitting ends).
  - One, Dash 6 (–6), (3/8) JIC tube assembly.

The tube assembly, P/N 231-058-00 can be purchased directly from FloScan Technical Support. The 90° NMPT x JIC elbow fitting, and the FlareTite fitting seals can be purchased at most hydraulic shops.

14. Flow sensor model numbers are molded into the colored plastic wire cap. Sensors are shipped in matched pairs. They must not be mixed on twin engine installations. Match codes are identified by a single stand-alone letter stamped into the sensor body, or from a colored sticker on the sensors body.
15. Model \*235 sensors are temperature compensated and stamped with their instruments serial number, xxxxF (Forward), xxxxR (Return). \*235-2K Temp-Comp sensor kits are precisely calibrated and matched to each instrument. Sensors are labeled FORWARD and RETURN and must be installed in these positions for proper operation. The instrument head serial number must match the flow sensor(s) serial number.
16. If there is a shut-off valve in the return line, do not operate the engine with the valve closed. If the engine is run with the valve closed, fuel return line pressure could exceed the FloScan Return Sensor pressure rating of 100 PSI.

**NOTE: Minimize the number of 90° elbows and pipe fittings on the sensor or pulsation dampers inlet port.** Excessive use may create a high vacuum, fuel restricting, pressure drop across the forward part of the fuel system. Refer to the engine owners’ manual for maximum fuel pump inlet vacuum. A vacuum gauge can be used to confirm that the system is within limits.

**CAUTION, DO NOT OVER TIGHTEN FITTINGS.** Over-tightening may crack the sensor’s body or pulsation damper’s base. Cracks cause leaks, and fuel leaks sometimes cause catastrophic explosions and fire. Assemble fittings with a Lubricating, Fuel Proof, Non or Semi Hardening pipe thread sealant designed for aluminum and stainless steel threads, (Loctite 567 or equivalent).  
**DO NOT USE TEFLON TAPE.**

## Series 5400(0)/5500(0)/56100/5800(0)/6500(0)/6600(0) AccuTroll & CruiseMaster, All Multi Function Instruments, & TwinScan®

### SET UP

**Wire & Switches:** Use 18 AWG stranded wire on runs under 50'. For runs over 50' use 16 AWG. Shielded wire is recommended for all Diesel systems and suggested for Inboard & I/O gasoline systems. Always, "Ground" the wire shield or shield drain wires in the engine room by connecting them to the bonding system or engine block. The double wiring harness for twin engine Pulse/NMEA Diesel installations is included in all, (97/9800(0)) kits. FloScan suggests using J-Boxes, Terminal Blocks, and three conductor cables between diesel sensors and instrument to make wiring easier.

Install Single Pole Single Throw (SPST) switches for Totalizer Reset, Port–Starboard Select, Engine Hours / Synchronizer, and GPH / MPG, (switches are not included with kit). To determine which switch types are required for your system, refer to the table below. All instruments except TwinScan Tachometers require a totalizer reset switch.

| SYSTEM                        | TOTALIZER RESET              | PORT/STBD<br>Twin Engine Systems | HOURS/<br>SYNCH | GPH/<br>MPG | MPG/<br>SYNCH |
|-------------------------------|------------------------------|----------------------------------|-----------------|-------------|---------------|
| 5400(0)                       | SPST or Momentary <u>OFF</u> | SPST                             | NA              | NA          | NA            |
| 5500(0)/56100                 | SPST or Momentary <u>OFF</u> | SPST                             | NA              | NA          | NA            |
| 5800(0)                       | SPST or Momentary <u>OFF</u> | NA                               | NA              | NA          | NA            |
| 6500(0)/6600(0)               | SPST or Momentary <u>OFF</u> | NA                               | NA              | NA          | NA            |
| 65/6600(0) Cummins PT         | SPST or Momentary <u>OFF</u> | SPST                             | NA              | NA          | NA            |
| 7000/8000(0) Gasoline MFI     | SPST or Momentary <u>ON</u>  | SPST                             | SPST            | NA          | NA            |
| 71/8A00(0) MFI - Gasoline EFI | SPST or Momentary <u>ON</u>  | NA                               | NA              | NA          | NA            |
| 75/7600(0) Diesel MFI         | SPST or Momentary <u>ON</u>  | NA                               | NA              | NA          | NA            |
| 9000 Gasoline MFI             | SPST or Momentary <u>ON</u>  | SPST                             | SPST            | SPST        | NA            |
| 9A00(0) MFI - Gasoline EFI    | SPST or Momentary <u>ON</u>  | NA                               | NA              | SPST        | NA            |
| 95/96/97/9800(0)              | SPST or Momentary <u>ON</u>  | NA                               | NA              | SPST        | NA            |
| TwinScan GPH Meter            | SPST or Momentary <u>ON</u>  | NA                               | NA              | NA          | NA            |
| TwinScan Tachometer           | NA                           | NA                               | NA              | NA          | NA            |
| TwinScan GPH & Tachometer     | SPST or Momentary <u>ON</u>  | NA                               | NA              | NA          | SPST          |

NA = Not Applicable

**Grounding:** Each Black sensor wire must be connected directly to the Black, "Instrument Ground" wire. Use a single wire to connect the Black wire junction to the battery's negative terminal, or a ground buss.

**Power:** FloScan Instruments & sensors operate on 9 to 12 VDC. Voltages exceeding 16 VDC will damage equipment. 24 & 32 VDC systems must be reduced to 12 VDC. Two different types of voltage reducers are available through FloScan.

### WIRE CONNECTIONS

**Installation:** Connect wires one at a time and install heat shrink tubing before proceeding to the next wire, (refer to diagram). Connect ground wires first, (BLACK instrument ground wire to the BLACK sensor wires). Connect this junction to the battery's negative terminal or the ground buss. Connect all other wires leaving the Red power wires for last to prevent short circuits during installation.

**Splicing:** Splice or join individual wires per the diagram. Slide heat shrink tubing over the splices to prevent shorts. Do not seal splices until the installation is finished and has been tested.

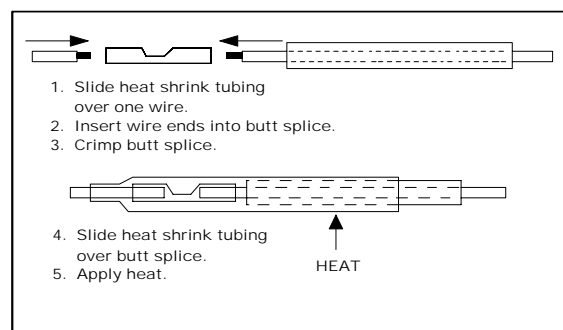

An adequate number of crimp-on connectors and heat-shrink tubing are included with system. The heat-shrink is a special type that will bond to wire insulation and make a watertight connection. See diagram for proper tubing application. Crimp-on connectors are sized for 18 or 20 gauge stranded wire.

## **Tachometer Wiring Information applies only to MFI & TwinScan Instrument Tachometers**

Tachometer signal wires on MFI & TwinScan Tachometers should be shielded.

For proper tachometer operation on gasoline EFI engines, (especially outboards) the engine Ground wire must be physically connected to the MFI or TwinScan instrument ground wire.

**Note:** FloScan recommends using dedicated 18 AWG shielded cable for tachometer signal wire connections. Always, “Ground” wire shields or the shield drain wire in the engine room by connecting to the bonding system or engine block.

### **MULTI FUNCTION & TWINSCAN INSTRUMENT TACHOMETERS for CARBURETOR & CLOSED LOOP EFI GASOLINE ENGINES POINTS or STANDARD ELECTRONIC IGNITIONS**

Inboard, & I/O Engines: Connect the YELLOW wire from pin # 8 to the distributor coil’s negative terminal. On twin engine systems the Yellow wire from pin # 8 connects to the port engine, the VIOLET wire from pin # 16 to starboard.

Outboard Engines: Outboard tachometers are connected to either the engine alternator or tachometer signal wire. Connect the YELLOW wire from pin # 8 to the engine alternator or tachometer signal wire. On twin engine systems the Yellow wire from pin # 8 connects to the port engine, the VIOLET wire from pin # 16 to starboard.

### **MULTI FUNCTION & TWINSCAN INSTRUMENT TACHOMETERS for CLOSED LOOP EFI GASOLINE ENGINES with CPU IGNITION SYSTEMS**

Inboard, I/O, & Outboard Engines: Connect the YELLOW wire from pin # 8 to the engines’ tachometer signal wire. On twin engine systems the Yellow wire from pin # 8 connects to the port engine, the VIOLET wire from pin # 16 to starboard.

Outboard Engines: Connect the YELLOW wire from pin # 8 to the engines’ tachometer signal wire. On twin engine systems the Yellow wire from pin # 8 connects to the port engine, the VIOLET wire from pin # 16 to starboard.

### **MULTI FUNCTION INSTRUMENT TACHOMETERS for OPEN RETURN EFI GASOLINE ENGINES with CPU IGNITION SYSTEMS**

Inboard & I/O Engines: Connect the YELLOW wire, pin # 8 to the engines’ tachometer signal wire.

### **MULTI FUNCTION INSTRUMENT TACHOMETERS - DIESEL ENGINES**

- Keep existing tachometer: Connect the YELLOW and VIOLET wires to the existing tachometer signal wires. If one lead is grounded at the pickup or alternator, connect the YELLOW wire to the tachometer signal wire. Connect the VIOLET wire to a ground buss.
- Replace existing tachometer: Connect the YELLOW and VIOLET wires to the existing magnetic pickup or signal generator. If one lead is grounded at the pickup or alternator, connect the YELLOW wire to the existing signal wire terminal at the tachometer and connect the VIOLET wire to a ground buss.
- Install as a new tachometer. On engine alternator installations, connect the YELLOW wire to the tachometer output terminal (usually marked “tach” or “sig”) and connect the VIOLET wire to a ground buss. For mechanically driven A-C signal generators and magnetic pickups, connect the YELLOW wire to one terminal and the VIOLET wire to the other.

### **TWINSCAN INSTRUMENT TACHOMETERS – DIESEL ENGINES**

- Connect the YELLOW wire to one terminal the Port tachometer sender, (AC signal generator, Magnetic pickup, or the engines’ alternators tach or sig terminal). Connect the VIOLET wire to the Starboard sender. The tachometer senders’ second terminal must be grounded.

## **FINAL ACTIONS**

Check Electrical Installation: Test all connections. Support and secure all dangling wires. Start engine and calibrate system.

# WIRING DIAGRAM

## Series 7500(0)/7600(0) Diesel Multifunction Instrument

### Instrument Connection Harness

| IN | FUNCTION                                | PIN | FUNCTION                     |
|----|---|-----|------------------------------|
| 1  | Not Connected                           | 9   | RED + 12VDC                  |
| 2  | Not Connected                           | 10  | GREEN Totalizer Reset Switch |
| 3  | Not Connected                           | 11  | Not Connected                |
| 4  | ORANGE +12V Illumination                | 12  | BLACK Jumper to Pin 13       |
| 5  | BLACK Battery Minus (-) or Minus Buss * | 13  | BLACK Jumper to Pin 12       |
| 6  | WHITE Forward Flow Sensor               | 14  | BROWN Return Flow Sensor     |
| 7  | Not Connected                           | 15  | BLACK Totalizer Reset Switch |
| 8  | YELLOW Tachometer Pick-Up               | 16  | VIOLET Tachometer Pick-Up    |

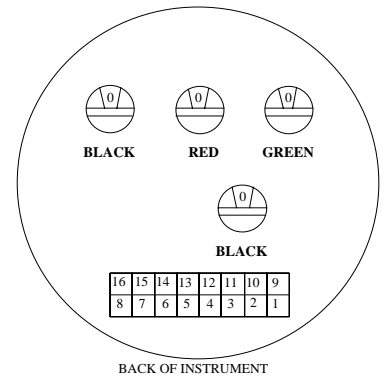

### Forward and Return Sensor Installations

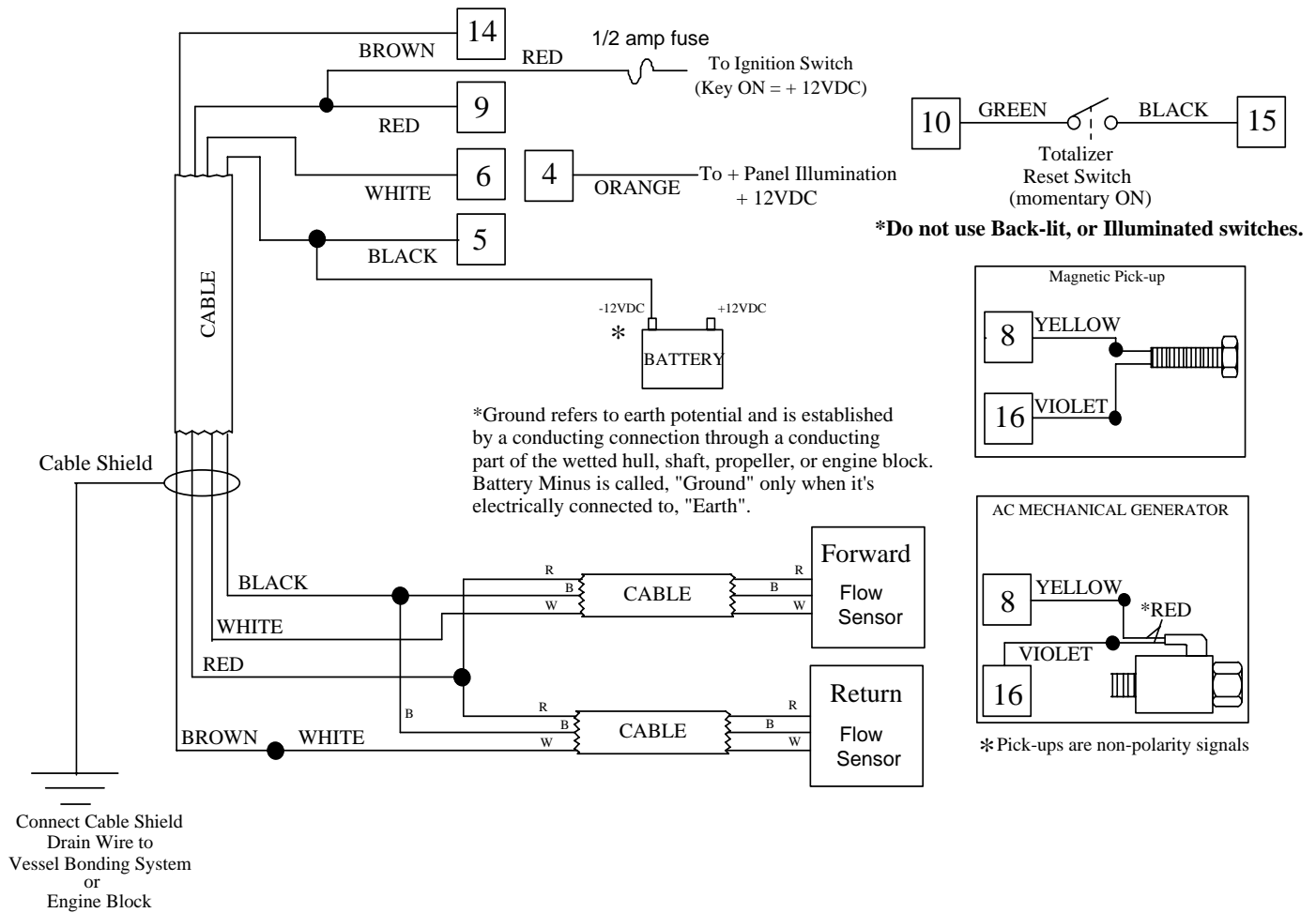

**NOTE:** Wiring Diagram for Diesel Systems requiring Forward and Return Flow Sensors.

(See reverse for single sensor wiring diagram)

### Instrument Connection Harness

| IN | FUNCTION                                | PIN | FUNCTION                     |
|----|---|-----|------------------------------|
| 1  | Not Connected                           | 9   | RED + 12VDC                  |
| 2  | Not Connected                           | 10  | GREEN Totalizer Reset Switch |
| 3  | Not Connected                           | 11  | Not Connected                |
| 4  | ORANGE +12V Illumination                | 12  | BLACK Jumper to Pin 13       |
| 5  | BLACK Battery Minus (-) or Minus Buss * | 13  | BLACK Jumper to Pin 12       |
| 6  | WHITE Forward Flow Sensor               | 14  | BROWN Not Connected          |
| 7  | Not Connected                           | 15  | BLACK Totalizer Reset Switch |
| 8  | YELLOW Tachometer Pick-Up               | 16  | VIOLET Tachometer Pick-Up    |

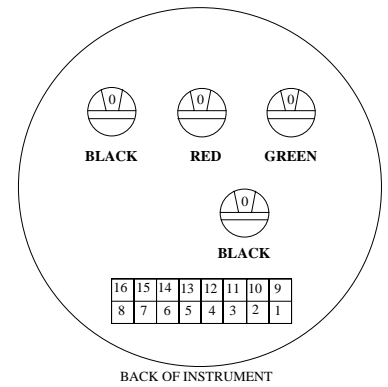

### Single Sensor Installations

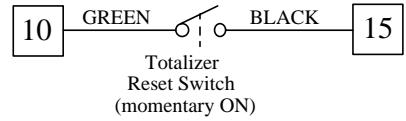
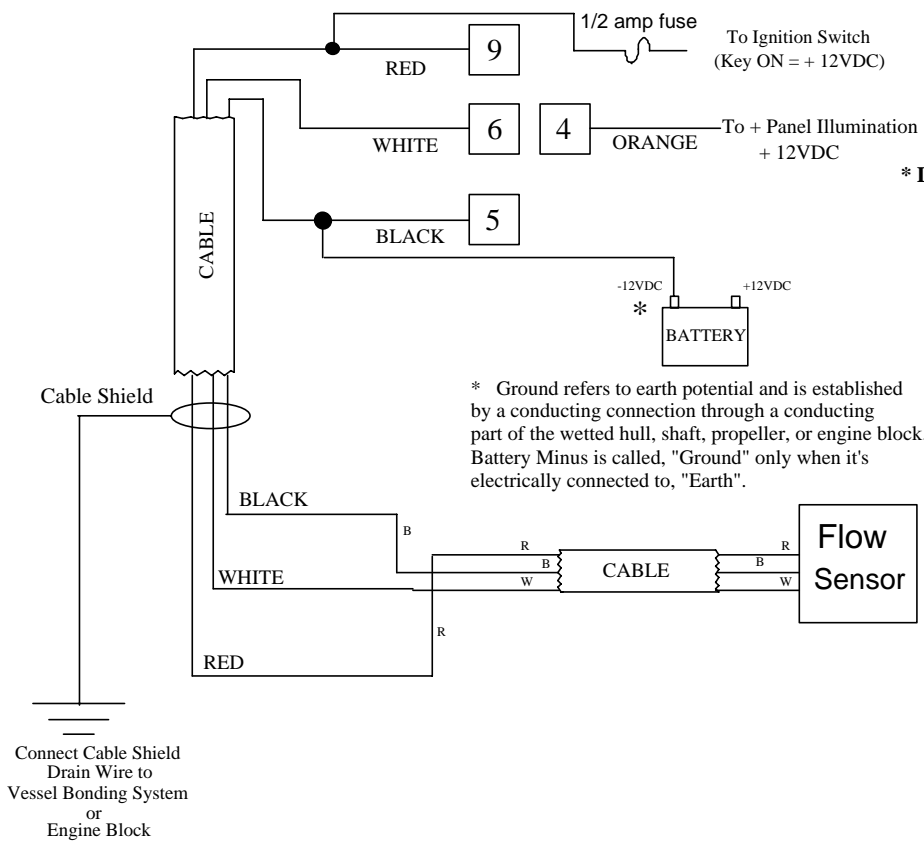

**\* Do not use Back-lit, or Illuminated switches**

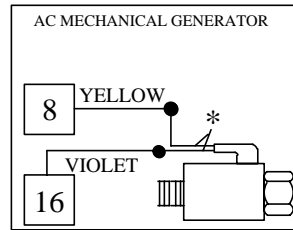
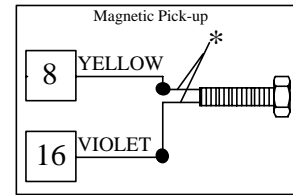

\* Pick-ups are non-polarity signals

**NOTE:** Wiring Diagram for Single sensor Diesel Systems.

## Series 7500/7600 8500/8600 9500/9600 Multifunction Instrument, Magnetic Pick-Up (INTEGER)

This instrument **MUST BE** calibrated to your specific engine in the following manner:

1. Determine the number of pulses generated by the Magnetic Pulse Source (Magnetic Pick-Up). Pulses are generated as a gear tooth passes the face of the Pick-Up. Pulses = the number of teeth of the gear (usually the flywheel) multiplied by the number of gear revolutions per crankshaft revolution. Contact your local engine dealer if you need help with finding this. You will need your engine serial number and configuration codes.
2. From the table below determine the number of pulses per crank shaft revolution.

*Example:* Pulses per crank shaft revolution = 212

3. Follow the row across and find the position to set the RED switch. For the 212 example in step 2, set the RED switch at D.
4. Follow the column up to find the position to set the GREEN switch. For the 212 example in step 2, set the GREEN switch at 3.

|               |   | GREEN SWITCH |     |     |     |     |     |     |     |     |     |     |     |     |     |     |     |
|---------------|---|--------------|-----|-----|-----|-----|-----|-----|-----|-----|-----|-----|-----|-----|-----|-----|-----|
|               |   | 0            | 1   | 2   | 3   | 4   | 5   | 6   | 7   | 8   | 9   | A   | B   | C   | D   | E   | F   |
| RED<br>SWITCH | 0 | 1            | 2   | 3   | 4   | 5   | 6   | 7   | 8   | 9   | 10  | 11  | 12  | 13  | 14  | 15  | 16  |
|               | 1 | 17           | 18  | 19  | 20  | 21  | 22  | 23  | 24  | 25  | 26  | 27  | 28  | 29  | 30  | 31  | 32  |
|               | 2 | 33           | 34  | 35  | 36  | 37  | 38  | 39  | 40  | 41  | 42  | 43  | 44  | 45  | 46  | 47  | 48  |
|               | 3 | 49           | 50  | 51  | 52  | 53  | 54  | 55  | 56  | 57  | 58  | 59  | 60  | 61  | 62  | 63  | 64  |
|               | 4 | 65           | 66  | 67  | 68  | 69  | 70  | 71  | 72  | 73  | 74  | 75  | 76  | 77  | 78  | 79  | 80  |
|               | 5 | 81           | 82  | 83  | 84  | 85  | 86  | 87  | 88  | 89  | 90  | 91  | 92  | 93  | 94  | 95  | 96  |
|               | 6 | 97           | 98  | 99  | 100 | 101 | 102 | 103 | 104 | 105 | 106 | 107 | 108 | 109 | 110 | 111 | 112 |
|               | 7 | 113          | 114 | 115 | 116 | 117 | 118 | 119 | 120 | 121 | 122 | 123 | 124 | 125 | 126 | 127 | 128 |
|               | 8 | 129          | 130 | 131 | 132 | 133 | 134 | 135 | 136 | 137 | 138 | 139 | 140 | 141 | 142 | 143 | 144 |
|               | 9 | 145          | 146 | 147 | 148 | 149 | 150 | 151 | 152 | 153 | 154 | 155 | 156 | 157 | 158 | 159 | 160 |
|               | A | 161          | 162 | 163 | 164 | 165 | 166 | 167 | 168 | 169 | 170 | 171 | 172 | 173 | 174 | 175 | 176 |
|               | B | 177          | 178 | 179 | 180 | 181 | 182 | 183 | 184 | 185 | 186 | 187 | 188 | 189 | 190 | 191 | 192 |
|               | C | 193          | 194 | 195 | 196 | 197 | 198 | 199 | 200 | 201 | 202 | 203 | 204 | 205 | 206 | 207 | 208 |
|               | D | 209          | 210 | 211 | 212 | 213 | 214 | 215 | 216 | 217 | 218 | 219 | 220 | 221 | 222 | 223 | 224 |
|               | E | 225          | 226 | 227 | 228 | 229 | 230 | 231 | 232 | 233 | 234 | 235 | 236 | 237 | 238 | 239 | 240 |
|               | F | 241          | 242 | 243 | 244 | 245 | 246 | 247 | 248 | 249 | 250 | 251 | 252 | 253 | 254 | 255 | 265 |

**NOTE:** You can check to ensure the correct number was properly set by putting the gauge into “show switches mode.” To do this, turn the power to the gauge OFF and then back ON. While the display is showing all “8”s, cycle the totalizer – reset switch from the reset position to the run position at least twice. The calibration will be displayed in the RPM window for about twenty seconds. The gauge will then go into diagnostic mode. To put the gauge back into normal operating mode, cycle the power OFF and back ON. Do not touch the reset switch while the display is showing all “8”s.



## AC Signal Generator Input

Switch Settings

| Poles | Drive Ratio | Green Switch | Red Switch |
|-------|-------------|--------------|------------|
| 4     | 0.5 to 1    | 1            | 0          |
| 4     | 1 to 1      | 3            | 0          |
| 4     | 2 to 1      | 7            | 0          |
| 8     | 0.5 to 1    | 3            | 0          |
| 8     | 1 to 1      | 7            | 0          |
| 8     | 2 to 1      | F            | 0          |
| 30    | 0.5 to 1    | E            | 0          |
| 30    | 1 to 1      | D            | 1          |
| 30    | 2 to 1      | B            | 3          |

### Alternator Input

The signal from the alternator input comes from one alternator winding before it's rectified. You may notice fluctuations in the tachometer due to belt slippage and varying alternator load.

### No Tachometer reading at lower RPMs

Until engine RPM reaches a certain point, the alternators output voltage will be too low for the tach to read. Installing a 12 VDC light across a DC power source (+12 VDC to ground) will increase the alternator load slightly, and cause its output voltage to increase to a usable level.

### Calibration

The tachometer can be calibrated by two methods:

#### I.

Calibrate to an existing tachometer. Rotate the RED and GREEN knobs on the back of the instrument until the two tachometers agree with each other. The accuracy of this method depends on the accuracy of the existing tachometer at the RPM to which you calibrate. Most analog tachometers are accurate to either  $\pm 50$  RPM or  $\pm 100$  RPM, with the center of the scale being the most accurate. If you set the calibration here and find a difference toward the minimum or maximum ends of the analog tachometer scale, it is probably due to the nonlinearity of the analog meter movement. This method may not be as accurate as #2 below.

#### II.

1. Calculate the number of pulses per crank shaft revolution. To find the number of crank shaft pulses per revolution, divide the diameter of the engines crank shaft pulley by the diameter of the alternator pulley, and multiply by the number of alternator pulses.

$$\frac{\text{Diameter of Crank Shaft Pulley}}{\text{Diameter of Alternator Pulley}} \times \text{Number of Alternator Pulses} = \text{Pulses per Revolution}$$

2. Locate the number of pulses per crank shaft revolution from the table, select the number closest to the actual pulses per crank shaft revolution. Set the RED and GREEN switches on the back of the instrument accordingly.

**Example:** A Motorola alternator has 12 pulses (12 pulses per revolution)  
 Crank shaft pulley = 10" diameter  
 Alternator pulley = 4" diameter

$$12 \times 10/4 = \text{number of pulses per revolution}$$

$$12 \times 2.5 = 30 \text{ pulses per revolution}$$

## Series 75/7600(0), 85/8600(0), 95/9600(0) M & I Multifunction Instrument, Totalizer Calibration

This is a four-part calibration procedure. Part I covers adjusting a Generator's idle consumption and totalizer calibration. Part II covers propulsion engine idle consumption, (forward and return sensor systems only). Part III helps determine the optimum fuel tank configuration. Part IV finalizes totalizer calibration for overall accuracy.

### PART I: Generators & Diesel Electric Propulsion Engines

Contact the engine dealer or refer to the engine manual-data sheet and determine the engines:

- No load fuel consumption.
- The 10 % or 25% load, fuel consumption.

#### Idle Consumption Adjustment for Forward and Return, Two Sensor Generator Systems

- Start and run the engine until it is at operating temperature.
- Referring to the switch diagram, rotate the Upper and Lower Black Switches to, "0".
- With no load, verify that the engine is running at the correct RPM, (usually 1200, 1500 or 1800).
- Rotate the Lower Black switch until the GPH reading matches the manufacturer's no load fuel consumption specification.

#### Totalizer Calibration for Forward and Return, Two Sensor Generator Systems

- Put a 10% or 25% load on the generator.
- Rotate the Upper Black switch until the GPH reading matches the manufacturer's 10% or 25% load fuel consumption listing.

**NOTE:** Generator and Auxiliary engines turning at 1200, 1500 or 1800 RPM will consume much more fuel at No Load, than propulsion engines. If you are unable to obtain the engine manufacturer's consumption data proceed to Part's II and IV below. You should triple the readings in Part II, Table 1.

### PART II: Idle Consumption Adjustment for Forward and Return Sensor Propulsion Engine Systems

- Start and run engine(s) until they're at operating temperature.
- Referring to the switch diagram, rotate the Upper and Lower Black Switches to, "0".
- Increase engine speed to 1800 RPM for one minute. This purges any trapped air from the system.
- Return engine speed to low idle and determine its' consumption from Table 1 below.

| Table 1 No Load Idle Consumption |                        |                        |
|----------------------------------|------------------------|------------------------|
| HP                               | Non-Turbo              | w/Turbo                |
| 100-400                          | 0.1-0.5 GPH, (1-2 LPH) | 0.3-0.7 GPH, (2-3 LPH) |
| 400-750                          | 0.8 GPH, (3 LPH)       | 1.0 GPH, (3-4 LPH)     |
| 750-1000                         | 1.0 GPH, (4 LPH)       | 1.5 GPH, (5-6 LPH)     |
| 1000-1250                        | 2.0 GPH, (7-8 LPH)     | 2.5 GPH, (9-10 LPH)    |
| 1250-1500                        | 3.0 GPH, (11-12 LPH)   | 3.5 GPH, (13-14 LPH)   |
| 1500-2000                        | 3.5 GPH, (13-14 LPH)   | 4.0 GPH, (15-16 LPH)   |
| 2000-3000                        | 4.5 GPH, (17 LPH)      | 5.0 GPH, (18-19 LPH)   |

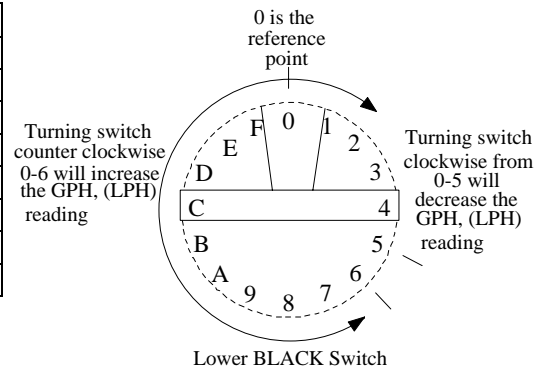

- Rotate Lower Black Switch until the idle GPH, (LPH) reading matches engine HP from Table 1.

**NOTE:** At this point, idle consumption is approximate. It establishes operating parameters for final calibration. On G model instruments, the **Green Switch** replaces the **Lower Black Switch**. G Instruments were discontinued in 1999.

**Part III: Determining Optimum Tank Configuration & Cruise RPM**

- Determine the optimum fuel tank configuration for your vessel. If possible, single engine vessels should draw and return fuel to a single tank. On twin engine vessels, try to configure the fuel system so that each engine draws and returns fuel to its' own dedicated tank. If your twin engine vessel has only a single tank, equal consumption rates for both engines must be assumed.
- Close any cross connect or limber line valves between tanks during calibration.
- Take your vessel for a short cruise. Using the GPH, (LPH) reading as a guide, determine the best cruising RPM for the way you normally operate. Don't be concerned that the readings are slightly off. Calibration is most accurate when done at a single cruising RPM.

**Part IV: Final Calibration**

- Return to the fuel dock and top off the fuel tank(s).
- Reset the totalizer so that the GALLONS, (LITERS) window reading is zero.
- Operate the generator under load, or take the vessel for a cruise. Once underway, steam at your optimal cruising RPM, (Determined in Part Iii). Consume a minimum of 20 to 30 gallons, (75 to 115 liters) of fuel per engine. Higher consumption gives better accuracy.
- After consuming some fuel, return to the fuel dock and top off the fuel tank(s).
- Compare the Gallons, (Liters) window reading to the fuel pump reading.
- Calculate the percentage difference between the fuel pump & Gallons, (Liters) readings; (**Refer to Examples I & II below**).
- Determine if the totalizer is reading High or LOW.
- Rotate the **Upper Black Switch** until the **GALLONS, (Liters)** window matches the fuel pump reading.
- Starting at, "0" rotating the Upper BLACK Switch in a clockwise direction increases the Totalizer readings by 2% for each click.
- Rotating the switch in a counter-clockwise direction decreases Totalizer readings by 2%.
- Totalizer readings can be increased by 10%, or reduced by 20%.

**Single Engine Vessels:** Please refer to Example 1, Port system.

**Example 1:** Twin engine vessel with two, dedicated fuel tanks, (For single engine vessels with a single tank, use either the Port or Starboard system calibration procedure in Example 1).

After steaming and returning to refuel. The Port tank took 89.7 gallons, (339.5 liters). Its' totalizer reads 94.2 gallons, (356.5 liters). The Starboard tank took 93.2 gallons, (352.8 liters) and its' totalizer reads 87.9 gallons, (332.7 liters).

- Using the formula, calculate the percentage difference between the Totalizer reading and actual fuel consumption.

$$\frac{\text{Difference in Gallons, (Liters)}}{\text{Totalizer Reading}} \times 100$$

Port System Calibration

- Find the difference between the totalizer and fuel pump readings:  
**[94.2 gallon, (356.5 liter) totalizer reading] – [89.7 gallon, (339.5 liter) pump reading] = 4.5 gallon, (17.3 liter) difference.**
- Determine percentage difference between readings:  
**[4.5 gallon, (17.0 liter) difference] ÷ [94.2 gallon, (356.5 liter) totalizer reading] = .047 x 100 = 4.7% Higher difference.**
- To calibrate, rotate the Port MFI's Upper Black Switch Counter-Clockwise to position E, reducing totalizer reading by 4%.

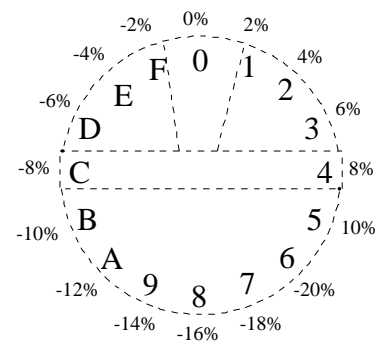

Upper BLACK switch

## Starboard System Calibration

- Find the difference between the totalizer and fuel pump readings:  
**[93.2 gallon, (24.4 liter) fuel pump reading] – [87.9 gallon, (332.7 liter) totalizer reading]= 5.3 gallon, (20.1 liter) difference.**
- Determine percentage difference between readings:  
**(5.3 gallon, (20.1 liter) difference) ÷ (87.9 gallon, (332.7 liter) totalizer reading) = .060 x 100 = 6% Lower difference.**
- To calibrate, rotate the Starboard MFI's Upper Black Switch Clockwise to position 3, increasing totalizer reading by 6%.

**Example 2:** Twin engine vessel with a single fuel tank.

## Port System Calibration

After refueling the tank took 182.9 gallons, (692 liters). The Port Totalizer reads 94.2 gallons, (356.6 liters) and the Starboard reads 87.9 gallons, (332.7 liters). With a single tank, you must assume that each engine burned 91.5 gallons, (346.3 liters).

- Find the difference between the totalizer and fuel pump readings:  
**[94.2 gallon, (356.5 liter) totalizer reading] – [91.5 gallon, (346.3 liter) assumed burn] = 2.7 gallon, (10.2 liter) difference.**
- Determine percentage difference between readings:  
**[2.7 gallon, (10.2 liter) difference] ÷ [94.2 gallon, (356.5 liter) totalizer reading] = .028 x 100 = 2.8% Higher difference.**
- To calibrate, rotate the Port MFI's Upper Black Switch Counter-Clockwise to position F, reducing its' totalizer reading by 2%.

## Starboard System Calibration

- Find the difference between the totalizer and fuel pump readings:  
**[91.5 gallon, (346.3 liter) assumed burn] - [87.9 gallon, (332.7 liter) totalizer reading] = 3.6 gallon, (13.6 liter) difference.**
- Determine percentage difference between readings:  
**[3.6 gallon, (13.6 liter) difference] ÷ [87.9 gallon, (332.7 liter) totalizer reading] = .041 x 100 = 4.1% Lower difference.**
- To calibrate, rotate the Starboard MFI's Upper Black Switch Clockwise to position 2, increasing its' totalizer reading by 4%.

This completes system calibration. The Instrument should be within 5% of actual consumption. Calibrating a second time should bring it to within 3%, especially on twin engine, single tank vessels. Larger fuel burns increase calibration accuracy.

Drastically changing operating habits, (Changing from mostly cruising to mostly trolling) may affect totalizer accuracy. If this occurs, re-calibration may be necessary.



## Series 7500/7600 8500/8600 9500/9600 Multifunction Instrument

BEFORE CALLING FOR ASSISTANCE, COMPLETE THESE TROUBLESHOOTING CHECKS AND RECORD YOUR FINDINGS. TECHNICAL SUPPORT REQUIRES THIS INFORMATION BEFORE A RETURN AUTHORIZATION WILL BE ISSUED. IT TAKES ABOUT 20 MINUTES AND IS VERY IMPORTANT IN ANALYZING SYSTEM PROBLEMS.

Before starting, record Instrument model number and switch settings.

MODEL # \_\_\_\_\_

SERIAL # \_\_\_\_\_

UPPER BLACK \_\_\_\_\_ RED \_\_\_\_\_ GREEN \_\_\_\_\_

LOWER BLACK or RECESSED ARROW \_\_\_\_\_

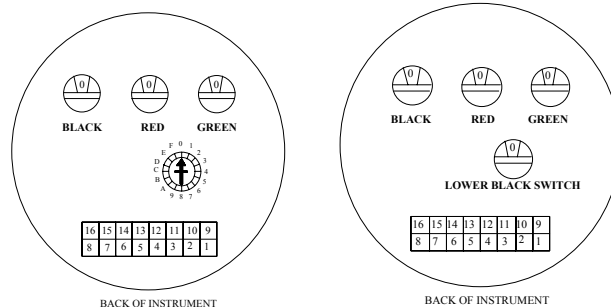

| FAULT                                    | PROBABLE CAUSE                                  | SEE SECTION:                   |
|--|---|--------------------------------|
| Blank LCD Display                        | Wiring  | Sections II, III               |
| No Back-Lighting                         | Wiring  | Sections III                   |
| High or Low Totalizer reading. Over 10%. | Calibration                                     | Calibration sheet              |
|  | Incorrect flow sensor                           | Operations sheet               |
|  | Incorrect switch settings                       | Calibration sheet              |
|  | Vacuum leak                                     | Section IX                     |
| Fluctuating GPH Readings                 | Vacuum leak / Pulsations                        | Sections VIII, IX, X           |
| No GPH or Totalizer Readings             | Wiring  | Sections II, V, VI             |
|  | Sensor orientation                              | Installation sheet, Section IV |
| High, Low or No Tachometer Reading       | Wiring  | Installation sheet, Section II |
|  | Calibration                                     | Calibration sheet              |
|  | Continuity                                      | Section VI                     |
|  | In-synch with engine or Glen Denning cable whip | Section VII                    |
| No Forward or Return Sensor Readings     | Wiring /Instrument failure                      | Sections I, II, IV, V, VI      |
|  | Sensor Failure                                  | Section I, IV                  |
| High Forward or Return Sensor Readings   | Vacuum Leak                                     | Section IX                     |
|  | Incorrect switch settings                       | Calibration sheet              |
|  | Sensor orientation                              | Section XI                     |

### I. DIAGNOSTIC TEST:

1. Start engine(s). For 2 seconds after powering up, the Instrument will show all 8s. During this time, quickly cycle the Totalizer-Reset Switch from its' run position to reset and back at least twice. This puts the Instrument into **Show Switches Mode** for 20 seconds. Record these readings below.

**HOURS:** \_\_\_\_\_ : \_\_\_\_\_

**RPM:** \_\_\_\_\_

**GPH:** \_\_\_\_\_

**GALLONS:** \_\_\_\_\_

After 20 seconds, the Instrument automatically goes into diagnostic mode. A minus sign (-) in the GALLONS window indicates when this occurs. The Instrument remains in diagnostic mode until power is secured.



**NOTE:** This may not be seen on digital voltmeters.

4. With engine(s) idling, measure and record voltage between the RED power and BLACK ground wires on the Return Sensor, (If used). Voltage should be 12 to 14 VDC. \_\_\_\_\_ VDC
5. Move the voltmeters' negative lead to the White (Signal) wire. With engine idling, measure and record the voltage. Readings between 4 and 10 VDC usually indicate a good sensor. \_\_\_\_\_ VDC
6. Stop the engine and observe the voltmeter. Voltage readings should fluctuate between a high of 9 to 12 VDC, and a low of 0 to 4 VDC as the Sensors' turbine slows to a stop. \_\_\_\_\_ VDC

**NOTE:** This may not be seen on digital voltmeters.

7. The Sensor(s) may be defective if voltage readings in steps 3 & 5 remain constant. \_\_\_\_\_ VDC
8. If signal voltages in steps 3 & 5 are ok, go to the backside of the MFI Instrument. With engine(s) running, measure and record voltage across the Red & White, (Forward Sensor) and Red & Brown, (Return Sensor) signal wires. The MFI voltage readings should match the Sensor readings. This verifies that the Sensors' signal is reaching the MFI. If voltage is not present, there is a wiring problem. \_\_\_\_\_ VDC

#### **V. MFI SENSOR INPUT TEST**

1. Disconnect the WHITE and BROWN signal wires at the MFI Instrument harness. Connect a course thread, (½ -13) or similar non-plated bolt to the Black wire.
2. Run the WHITE wire up and down the bolt threads. This generates a pulse, which should make numbers in the GPH window start counting up. The totalizer should also eventually start counting. Faster movements give higher readings.
3. Run the BROWN wire up and down the bolt threads. This generates a pulse, which should make numbers in the GPH window start counting up. The totalizer should also eventually start counting. Faster movements give higher readings.

#### **VI. CONTINUITY TEST**

1. Continuity testing requires access to the back of the Instrument and an Ohmmeter. It verifies that wires are not broken, shorted to ground, another wire, or to power. Before starting, secure all power, and disconnect the Molex connector from the Instrument. This test checks the WHITE, BROWN, YELLOW, VIOLET, and BLACK wires.
2. Disconnect the WHITE and BLACK wire harness conductors from the WHITE and BLACK Port Sensor wires. Connect a jumper from the WHITE wiring harness conductor to a known good ground. At the Molex connector, connect an Ohmmeter lead to its' WHITE wire. Connect the other Ohmmeter lead to a known good ground. The Ohmmeter should read approximately 0.1 to 3 Ω. \_\_\_\_\_ (Ohm Reading)
3. Disconnect the BROWN and BLACK wire harness conductors from the WHITE and BLACK Starboard Sensor wires. Connect a jumper from the BROWN wiring harness conductor to a known good ground. At the Molex connector, connect an Ohmmeter lead to its' BROWN wire. Connect the other Ohmmeter lead to a known good ground. The Ohmmeter should read approximately 0.1 to 3 Ω. \_\_\_\_\_ (Ohm Reading)
4. Disconnect the YELLOW wire harness conductor from the Port Tachometer Sender. Connect a jumper from the YELLOW wiring harness conductor to a known good ground. At the Molex connector, connect an Ohmmeter lead to its' YELLOW wire. Connect the other Ohmmeter lead to a known good ground. The Ohmmeter should read approximately 0.1 to 3Ω. \_\_\_\_\_ (Ohm Reading)
5. Disconnect the VIOLET wire harness conductor from the Starboard Tachometer Sender. Connect a jumper from the VIOLET wiring harness conductor to a known good ground. At the Molex connector, connect an Ohmmeter lead to its' VIOLET wire. Connect the other Ohmmeter lead to a known good ground. The Ohmmeter should read approximately 0.1 to 3Ω. \_\_\_\_\_ (Ohm Reading)

#### **VII. TACHOMETER PROBLEMS**

**Note:** Refer to the engine owners' manual, wiring diagram, installation, and calibration instructions for parts A, B, & C below.

##### **A. NO READING.**

8/30/2004

7000-074-00D

**FloScan Instrument Company, Inc.**  
3016 NE Blakeley Street, Seattle, WA 98105

Tel: (206) 524-6625  
Email: [service@floscan.com](mailto:service@floscan.com)

Fax: (206) 523-4961  
[Http://www.floscan.com](http://www.floscan.com)



1. Check continuity of the YELLOW and VIOLET Tachometer signal wires, (Section VI). Verify that the tachometer signal wires are connected at the correct signal output point.
2. Disconnect either the YELLOW or VIOLET Tachometer signal wire from the Tachometer Sender. Connect an Ohmmeter to the two sender wires and measure its' resistance. AC Signal Generators should measure approximately 180  $\Omega$ , ( $\pm$ ) 10%. Magnetic Pick-ups can measure between 100 to 800  $\Omega$  depending on manufacturer.
3. Next connect an AC Voltmeter to the sender wires. Both AC Signal Generator and Magnetic Pick-up senders should produce at least several volts at idle.
4. If the voltmeter reads "0" on an AC Signal Generator, it may not be properly attached to its drive port. Verify that its' drive shaft and tang are installed correctly.
5. If the voltmeter reads, "0" on a Magnetic Pick-up sender, it may not be installed correctly. With engine stopped, loosen its' lock nut. Turn the sender clockwise until it bottoms out. Back the sender out 1/8<sup>th</sup> to 1/4<sup>th</sup> turn. Turn the engine over by hand, or slowly jog it to verify adequate clearance.
6. Engine alternators tend to be an inaccurate Tachometer signal source, especially at low Rpm's. The engine may have to be revved up before the Tachometer will read.

#### **B. HIGH OR LOW READINGS.**

1. Verify that the Tachometer is calibrated correctly.

#### **C. FLUCTUATING READINGS.**

1. Listen to your engine(s). If engine speed cycles up and down, (when idling or underway) the tachometer reading will follow. This does not indicate a problem with the Tachometer, but may indicate engine problems.
2. Verify that wiring connections are tight, clean and dry. Check continuity while shaking the wires. Ohm readings should be near zero and remain steady while shaking.
3. Verify that the tachometer signal wires are connected at the correct signal output point.

#### **VIII. PULSATION PROBLEMS**

A stiff anti-siphon valve(s) or miss-plumbed Pulsation Damper(s) can cause fluctuating GPH readings. These are most pronounced at low Rpm's and tend to disappear around mid throttle. They are annoying, but won't affect totalizer accuracy. To eliminate, repair or replace any defective valves, or re-plumb dampers according to the Fuel Flow Schematic Instructions.

#### **IX. FINDING FUEL SYSTEM VACUUM LEAKS**

Fluctuating GPH and High Totalizer Readings are usually caused by a small vacuum leak between the fuel tank and fuel pump inlet. Fluctuations tend to be between 2 and 4 GPH. These vacuum leaks also affect totalizer accuracy, causing it to read 15 to 100% high. Larger leaks produce greater fluctuations and higher readings. They generally do not affect engine performance.

Finding suction leaks can be time-consuming. When approached properly, they can usually be found and repaired quickly. Two common places for suction leaks to occur are at the primary fuel filter - water separator, and/or a loose valve stem packing nut.

Remove the filter housing and coat all o-rings, gaskets and sealing surfaces with a medium to heavy grease, (**Do not use oil**) and reassemble. Grease all valve stem packings and gently tighten gland nuts. Don't over tighten, valve handles should turn freely. Tighten all hose clamps and compression fittings. Don't over tighten. Run the engine for 5 to 10 minutes observing GPH readings. If you've found the problem, fluctuations should be reduced to less than 1/2 GPH.

If the problem persists, temporarily install a clear piece of fuel resistant hose downstream of the forward flow sensor. Run the engine and watch for a stream of small bubbles in the clear hose, or an occasional larger bubble. Sometimes shining a light through the hose makes bubbles easier to see.

Observe the clear hose while shaking the fuel lines. If the bubble stream continually increases or decreases you've found the leak area. Repair or replace as needed. If this occurs one-time, you probably dislodged some trapped air.

If the leak hasn't been found, the last step is to inspect each pipe joint. Thread sealant should be visible around each joint. If not, that joint is suspect and must be resealed. After resealing run the engine for a few minutes to purge any remaining air. There should now be bubble free fuel running through the clear hose. If bubbles are still present a leak was missed. Recheck your work. After all the leaks are stopped, remove the clear hose.

## X. FUEL FILTERS

A dirty Primary fuel filter, or one that is too fine (1-25 micron) will draw vapor bubbles out of the fuel, causing fluctuations and high readings. Replace it with a new 30-micron filter.

## XI. FLOW SENSOR ORIENTATION

Sensor orientation is critical for proper operation. All Sensors have their inlet and outlet ports clearly marked (**IN / OUT** or **→ →**). This identifies fuel flow direction. The Sensor must be, “Plumbed” correctly for it to operate properly. There is an additional single arrow on the Sensor body. It is crucial that this single arrow points up **↑**.

## XII. LOW RPM OPERATION

At idle, under a no load condition, it is common for GPH readings to fluctuate slightly. These fluctuations are caused by the engine governor regulating fuel flow to maintain a steady engine RPM.

## XIII. NMEA 0183 Input, MPG, (Nautical) Miles per Gallon Problems:

### Error Codes

| Display      | Reason  | Cause  |
|--------------|---|--|
| <b>OFF</b>   | No signal activity present on NMEA 0183 terminals for four seconds                                | GPS / LORAN-C OFF<br>NMEA OUTPUT not selected<br>Leads not connected<br>A & B leads reversed       |
| <b>- - -</b> | Receiving valid NMEA 0183 Version 1.5 or 2.0 message, speed message invalid.                      | GPS satellite reception is poor<br>GPS / LORAN-C in startup mode                                   |
| <b>- 0 -</b> | Fuel flow reading below 0.1 GPH (LPH) (twin-both engines). Valid NMEA 0183 speed message present. | Engine(s) not running<br>Fuel flow reading problem.  |
| <b>Er1</b>   | Some pulsing activity present. No valid NMEA 0183 message received in last four seconds.          | Leads connected to wrong source<br>GPS / LORAN-C set to NMEA 0180 or 0182<br>A & B leads reversed. |
| <b>Er2</b>   | NMEA message detected. Missing “GPRMC” or “LCRMA” sentence.                                       | GPS / LORAN-C incompatible with NMEA 0183, ver. 1.5 or newer                                       |

1. An **OFF** display in the GPH/MPG window indicates the FloScan Instrument isn't receiving a NMEA 0183 speed signal from the GPS. Check wiring connections to the GPS, and verify that it is turned on.
2. A Dash, Dash, Dash, (- - -) display indicates the GPS is in startup mode, or satellite reception is poor.
3. A Dash 0 Dash, (- 0 -) display indicates a valid NMEA 0183 speed message is present, but that fuel flow readings are so low the FloScan Instrument is unable to compute a meaningful MPG figure. Dash 0 Dash, (- 0 -) may be displayed when motoring at low speeds, or when slowing down. When slowing down the FloScan Instrument may display ever-increasing MPG readings, go to Dash 0 Dash, (- 0 -) and start redisplaying ever-increasing readings again.
4. **Er1** indicates that the FloScan Instrument isn't receiving a valid NMEA 0183 message from the GPS. Check wiring connections to the GPS.
5. **Er2** indicates that, “GPRMC” or “LCRMA” is missing from the GPS NMEA 0183-speed signal message. Verify the GPS sending a NMEA 0183 version 1.5 or newer signal.

**This concludes system testing. If problems with your system persist, contact FloScan Technical Support with test results**